



A Resolution Amending and Approving a Utility Easement on City Property Located Along the East Side of Buckley Rd Between E. 96th Ave and E 88th Ave to United Power to Accommodate and Underground Electrical Distribution Line

10/21/2024

Overview

- An existing overhead electric line owned by United Power, Inc. is on east side of the abandoned Buckley Road
- United Power is needing to replace the existing line
- New line is proposed to be installed underground along the east side of Buckley Road located on City owned property
- New line extends from E. 96th Ave. to E. 88th Ave. and will serve the new development in the area
- New line will not be in conflict with future City facilities or infrastructure
- Previously approved easement needs to be adjusted.

Project Map

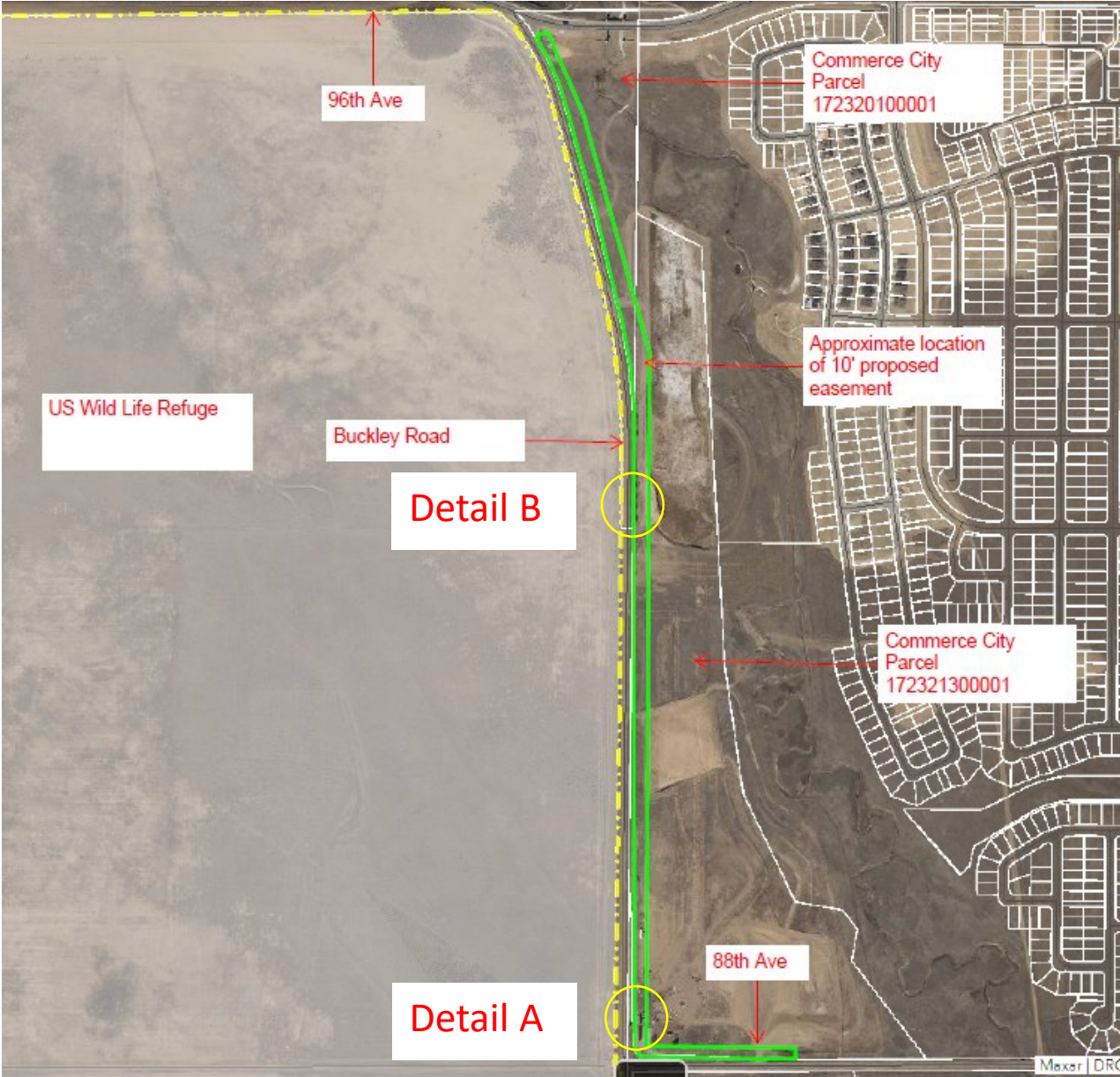

Original Illustration of the Legal Description (in the revised area)

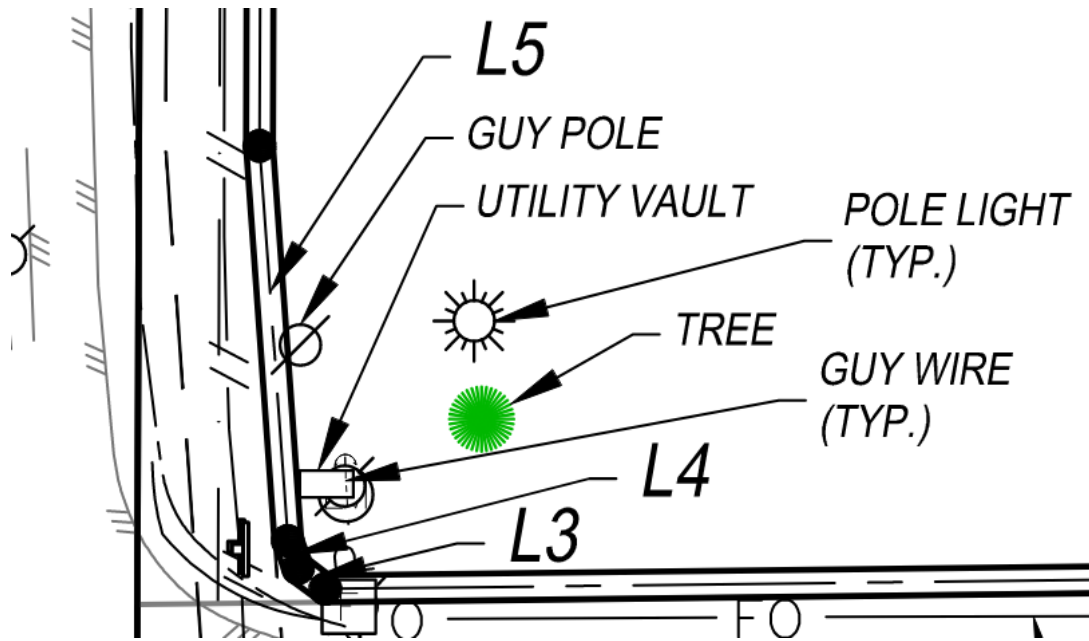

Detail A

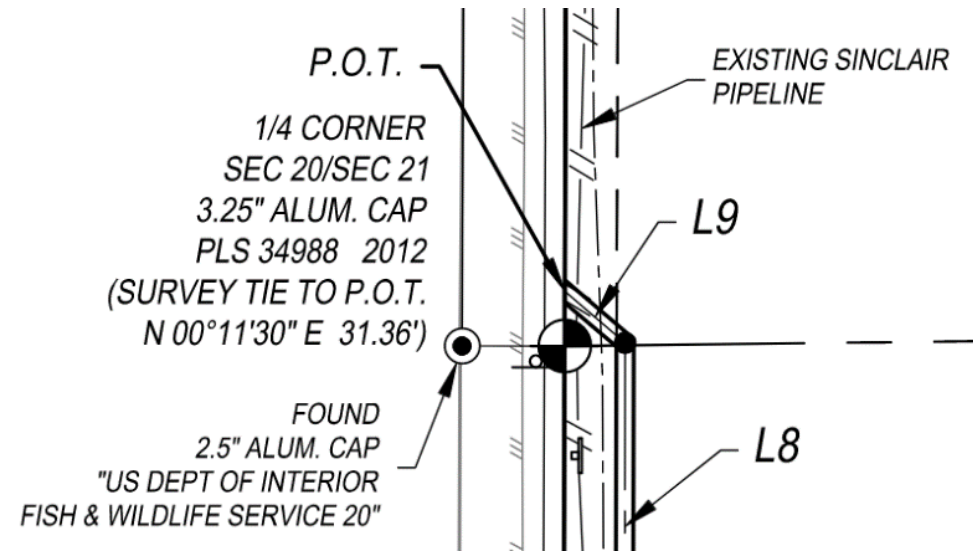

Detail B

Revised Legal Description (in the revised area)

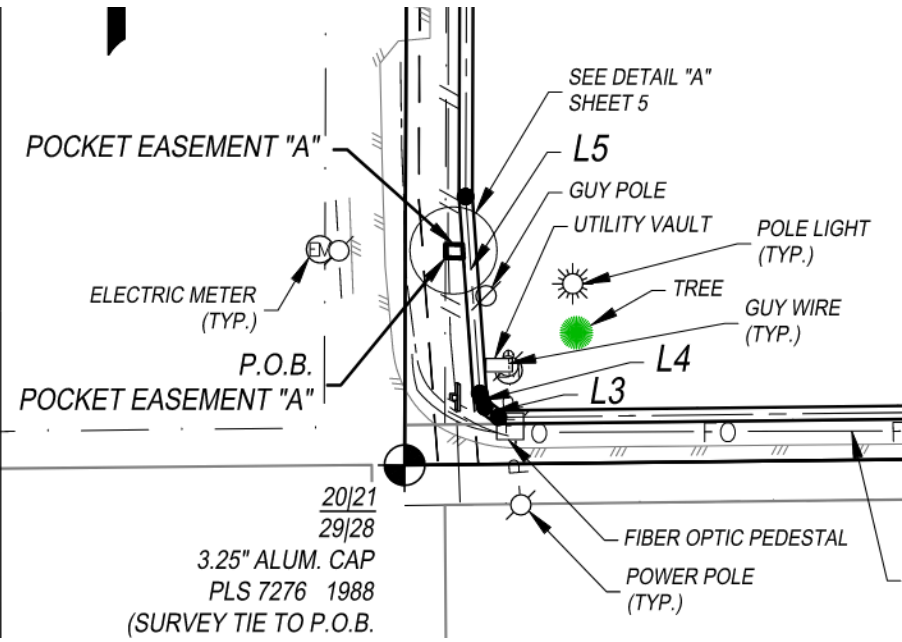

Detail A

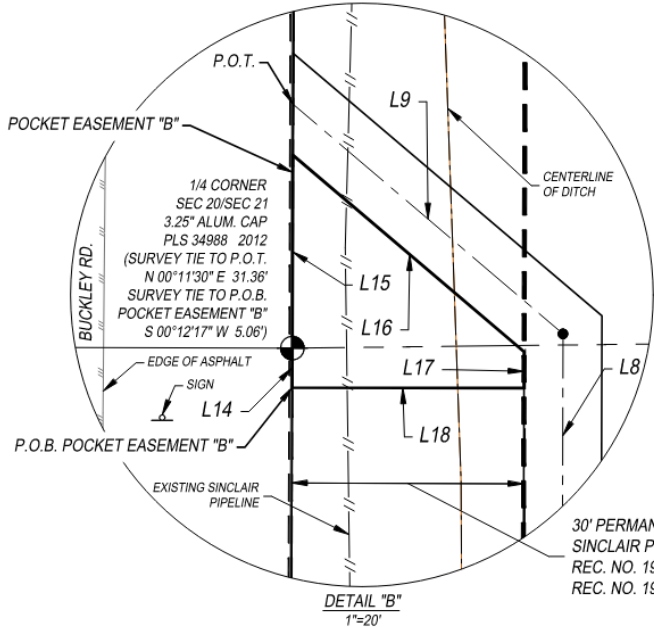

Detail B

POCKET EASEMENT "B"

LINE	BEARING
L14	N 00°12'17"
L15	N 00°11'30"
L16	S 49°38'25"
L17	S 00°09'30"
L18	N 89°50'30"

TOTAL AREA: 0.012 ACI



Next Steps

- Council approves easement revision
- United Power is acquiring ROW permit for staff approval
- UP to construct underground electric lines



Discussion