

CANAM PUD ZONE DOCUMENT

A PARCEL OF LAND LOCATED WITHIN SECTION 10, TOWNSHIP 2 SOUTH, RANGE 67 WEST OF THE SIXTH PRINCIPAL MERIDIAN, CITY OF COMMERCE CITY,
COUNTY OF ADAMS, STATE OF COLORADO

LEGAL DESCRIPTION

PARCEL 1 (TO BE ANNEXED):

A PARCEL OF LAND LOCATED IN THE NORTH HALF OF THE NORTHEAST QUARTER OF SECTION 10, TOWNSHIP 2 SOUTH, RANGE 67 WEST OF THE SIXTH PRINCIPAL MERIDIAN, CITY OF COMMERCE CITY, COUNTY OF ADAMS, STATE OF COLORADO, BEING MORE PARTICULARLY DESCRIBED AS FOLLOWS:

BASIS OF BEARING: ALL BEARINGS ARE GRID BEARINGS OF THE COLORADO STATE PLANE COORDINATE SYSTEM, CENTRAL ZONE (MODIFIED), NORTH AMERICAN DATUM 1983. BEARINGS ARE BASED ON THE NORTH LINE OF THE NORTHEAST QUARTER, SECTION 10, T2S, R67W, 6TH PRINCIPAL MERIDIAN AND IS CONSIDERED TO BEAR N89°18'07"E, MONUMENTED AS SHOWN. BEARINGS ARE REFERENCED TO THE CITY OF COMMERCE CITY CONTROL DIAGRAM, RECORDED AT BOOK 1, PAGE 3776 OF THE ADAMS COUNTY CLERK AND RECORDERS OFFICE, DATED JUNE 30, 1999.

COMMENCING AT THE NORTH QUARTER CORNER OF SAID SECTION 10;

THENCE S46°19'55"W, A DISTANCE OF 44.01 FEET TO THE NORTHEAST CORNER OF A PARCEL OF LAND RECORDED AT REC. NO. R0179253 OF THE ADAMS COUNTY CLERK & RECORDER OFFICE, ALSO BEING A POINT ON THE WEST RIGHT-OF-WAY LINE OF BELLE CREEK BLVD, A 62' PUBLIC RIGHT-OF-WAY SAID POINT BEING THE POINT OF BEGINNING; THENCE ALONG THE ANNEXATION BOUNDARY OF COMMERCE CITY, RECORDED AT RECEPTION NO. C0261218, N89°18'07"E, A DISTANCE OF 1285.12 FEET;

THENCE CONTINUING ALONG THE ANNEXATION BOUNDARY OF COMMERCE CITY, RECORDED AT REC. NO. B781151, AND BEING THE WEST LINE OF A RIGHT-OF-WAY DEED, RECORDED AT BOOK 358, PAGE 172, S00°18'29"E, A DISTANCE OF 645.47 FEET TO THE SOUTHWEST CORNER OF SAID RIGHT-OF-WAY DEED AND BEING A POINT ON THE NORTHWESTERLY RIGHT-OF-WAY OF STATE HIGHWAY 85;

THENCE S30°44'00"W, ALONG SAID NORTHWESTERLY RIGHT-OF-WAY LINE, WHICH IS ALSO THE ANNEXATION BOUNDARY OF COMMERCE CITY, RECORDED AT REC. NO. C04112997, A DISTANCE OF 750.21 FEET TO THE NORTHEAST CORNER OF TRACT J, BELLE CREEK SUBDIVISION FILING NO. 2, RECORDED AT RECEPTION NO. C0886382;

THENCE S89°25'51"W, ALONG THE NORTH LINE OF THE SAID BELLE CREEK SUBDIVISION FILING NO. 2, WHICH IS ALSO THE ANNEXATION BOUNDARY OF COMMERCE CITY RECORDED AT RECEPTION NO. C06455017, A DISTANCE OF 898.25 FEET TO THE SOUTHEAST CORNER OF A PARCEL OF LAND RECORDED AT REC. NO. R0179253 OF THE ADAMS COUNTY CLERK & RECORDER OFFICE, ALSO BEING A POINT ON SAID WEST RIGHT-OF-WAY LINE OF BELLE CREEK BOULEVARD;

THENCE DEPARTING THE ANNEXATION BOUNDARY OF COMMERCE CITY, N00°18'29"W, ALONG THE EAST LINE OF SAID PARCEL OF LAND RECORDED AT REC. NO. R0179253, A DISTANCE OF 1283.66 FEET TO THE POINT OF BEGINNING;

SAID PARCEL CONTAINS 35.064 ACRES (1,527,400 SQUARE FEET), MORE OR LESS.

TOGETHER WITH

COMMENCING AT THE NORTH QUARTER CORNER OF SAID SECTION 10;

THENCE ALONG THE NORTH LINE OF THE NORTHEAST QUARTER OF SAID SECTION 10, N89°18'07"E, A DISTANCE OF 1352.92 FEET; THENCE S00°41'53 E, A DISTANCE OF 30.00 FEET TO A POINT ON THE ANNEXATION BOUNDARY OF COMMERCE CITY, RECORDED AT REC. NO. B781151, SAID POINT BEING THE POINT OF BEGINNING;

THENCE N89°18'07"E, ALONG SAID ANNEXATION BOUNDARY OF COMMERCE CITY, A DISTANCE OF 237.83 FEET TO A POINT ON THE WEST RIGHT-OF-WAY LINE OF STATE HIGHWAY 85;

THENCE S03°37'32"E, ALONG SAID WEST RIGHT-OF-WAY LINE, WHICH IS ALSO THE ANNEXATION BOUNDARY OF COMMERCE CITY, RECORDED AT REC. NO. C0412997 A DISTANCE OF 79.00 FEET;

THENCE S30°44'00"W, ALONG SAID WEST RIGHT-OF-WAY LINE, WHICH IS ALSO THE ANNEXATION BOUNDARY OF COMMERCE CITY, RECORDED AT REC. NO. C0412997, A DISTANCE OF 470.06 FEET;

THENCE N00°18'29"W, ALONG THE EAST LINE OF SAID ANNEXATION BOUNDARY OF COMMERCE CITY. RECORDED AT REC. NO. B781151, A DISTANCE OF 480.00 FEET TO THE POINT OF BEGINNING;

SAID PARCEL CONTAINS 1.551 ACRES (67,556 SQUARE FEET), MORE OR LESS.

TOTAL ANNEXATION AREA CONTAINS 36.615 ACRES (1,594,956 SQUARE FEET), MORE OR LESS.

LEGAL DESCRIPTION CONTINUED ON SHEET 2.

VICINITY MAP

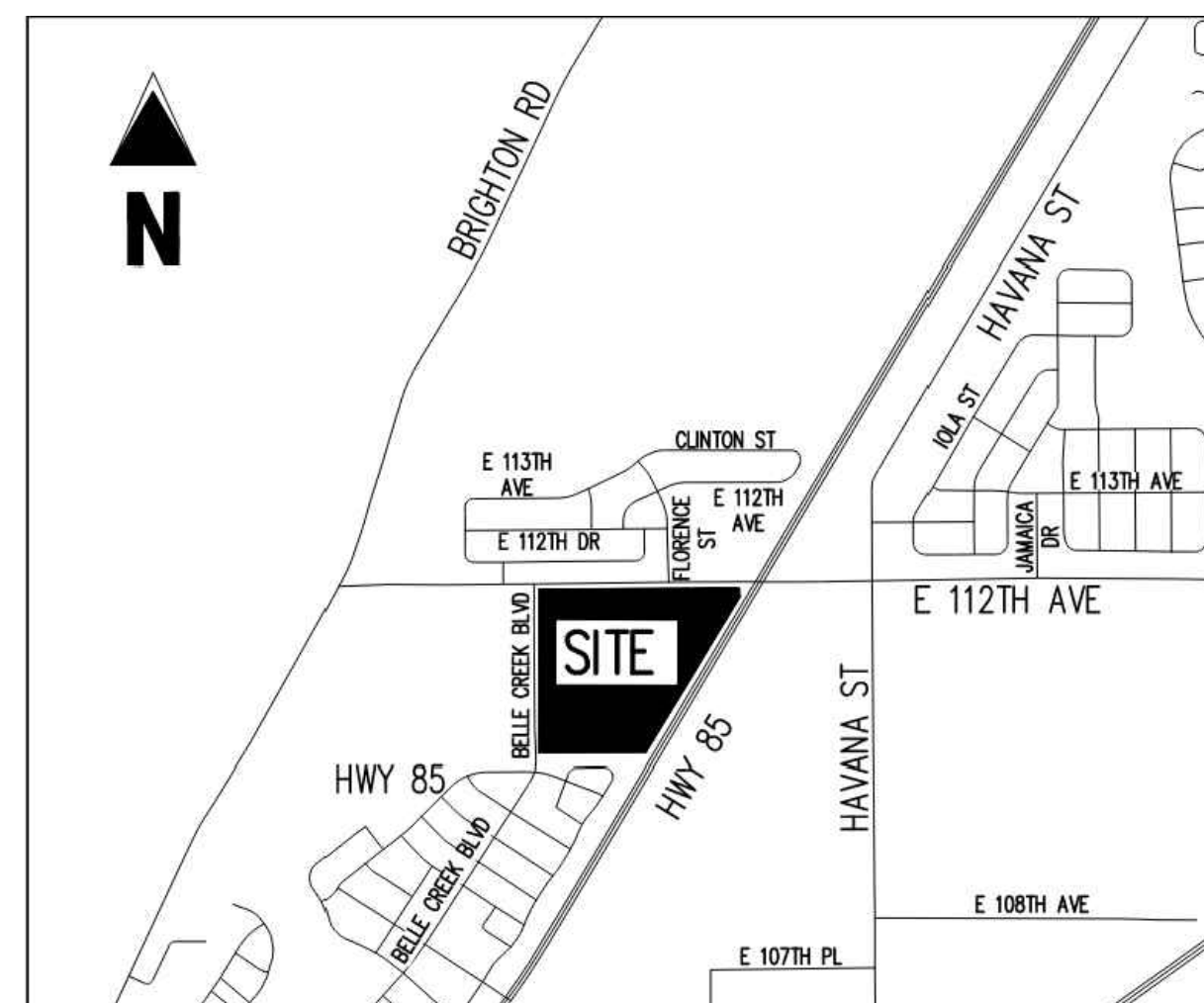

OWNER'S CERTIFICATE

Reisbeck Subdivision LLC, being the owner(s) of the property located in the City of Commerce City, County of Adams, State of Colorado, does hereby submit this Planned Development Zone Document and agree to platform under the terms noted herein.

By: _____
Name, Title
Reisbeck Subdivision LLC

Acknowledgement:

State of _____)
County of _____)ss.
City of _____)

The foregoing ownership certificate was acknowledged before me this _____ day of _____ AD 20 _____ by _____.

Notary Public _____

My commission expires _____

PLANNING COMMISSION CERTIFICATE

Approval by City of Commerce City, Planning Commission, this _____ day of _____ AD 20 _____.

Attest:

Chairperson _____

CITY COUNCIL CERTIFICATE

Approval by City of Commerce City, City Council, this _____ day of _____ AD 20 _____.

Attest:

City Clerk _____

Mayor _____

ADAMS COUNTY CLERK AND RECORDER'S CERTIFICATE

This PUD Zone Document was filed for record in the office of the Adams County Clerk and Recorder, in the State of Colorado, at _____, _____ M. on the _____ day of _____ AD 20 _____.

By: _____
County Clerk and Recorder

By: _____
Deputy

PROJECT TEAM

APPLICANT
QuikTrip Corporation
1499 West 120th Avenue Suite 110
Westminster, CO 80234
Contact: Mike Talcott
mtalcott@quiktrip.com

APPLICANT
United Development Companies
6900 E Belleview Ave Suite 300
Greenwood Village, CO 80111
Contact: Dan Sheldon
dsheldon@udcos.com

OWNER:
REISBECK SUBDIVISION LLC
2677 S. Clayton St
Denver, CO 80210
Contact: Suzanne Lamdin

PLANNER/LANDSCAPE ARCHITECT:
Norris Design
1101 Bannock Street
Denver, CO 80204
Contact: Daniel Jennings
djennings@norris-design.com

CIVIL ENGINEER
Kimley-Horn
4582 S. Ulster Street
Suite 1500
Denver, CO 80237
Contact: Shelby Madrid
303-228-2327
shelby.madrid@kimley-horn.com

SHEET INDEX

SHEET NO.	SHEET DESCRIPTION
1	COVER SHEET
2	COVER SHEET (CONTINUED)
3	PROJECT INTENT
4	PUD ZONING MAP
5	LAND USE STANDARDS
6	LOT TYPICALS
7	ALLOWED USES
8	STREET STANDARDS
9	ALLEY STANDARDS
10	SIGNAGE STANDARDS

CANAM
PLANNED UNIT DEVELOPMENT ZONE DOCUMENT
COMMERCE CITY, COLORADO

OWNER:
Reisbeck Subdivision LLC
2677 S. Clayton Street
Denver, CO 80210

DATE:
10/14/20 PUDZD 01
03/29/21 PUDZD 02
06/01/21 PUDZD 03
08/17/21 PUDZD 04

SHEET TITLE:
COVER SHEET

SHEET NUMBER:
1 OF 10

Reception # _____

CANAM PUD ZONE DOCUMENT

A PARCEL OF LAND LOCATED WITHIN SECTION 10, TOWNSHIP 2 SOUTH, RANGE 67 WEST OF THE SIXTH PRINCIPAL MERIDIAN, CITY OF COMMERCE CITY,
COUNTY OF ADAMS, STATE OF COLORADO

LEGAL DESCRIPTION (CONTINUED FROM PAGE 1)

PARCEL 2 (ALREADY ANNEXED):

A PARCEL OF LAND LOCATED IN THE NORTH HALF OF THE NORTHEAST QUARTER OF SECTION 10, TOWNSHIP 2 SOUTH, RANGE 67 WEST OF THE SIXTH PRINCIPAL MERIDIAN, CITY OF COMMERCE CITY, COUNTY OF ADAMS, STATE OF COLORADO, BEING MORE PARTICULARLY DESCRIBED AS FOLLOWS:

BASIS OF BEARING: ALL BEARINGS ARE GRID BEARINGS OF THE COLORADO STATE PLANE COORDINATE SYSTEM, CENTRAL ZONE (MODIFIED), NORTH AMERICAN DATUM 1983. BEARINGS ARE BASED ON THE NORTH LINE OF THE NORTHEAST QUARTER, SECTION 10, T2S, R67W, 6TH PRINCIPAL MERIDIAN AND IS CONSIDERED TO BEAR N89°18'07"E, MONUMENTED AS SHOWN. BEARINGS ARE REFERENCED TO THE CITY OF COMMERCE CITY CONTROL DIAGRAM, RECORDED AT BOOK 1, PAGE 3776 OF THE ADAMS COUNTY CLERK AND RECORDERS OFFICE, DATED JUNE 30, 1999.

COMMENCING AT THE NORTH QUARTER CORNER OF SAID SECTION 10;

THENCE WITH THE NORTH LINE OF THE NORTHEAST QUARTER OF SAID SECTION 10, N89°18'07"E, A TOTAL DISTANCE OF 1252.92 FEET; THENCE S00°41'53"E, A DISTANCE OF 30.00 FEET TO A POINT ON THE NORTH LINE OF ANNEXATION BOUNDARY MAP AN-82-87, SAID POINT BEING THE POINT OF BEGINNING;

THENCE WITH THE WEST LINE OF SAID ANNEXATION BOUNDARY MAP AN-82-87, BEING THE WEST LINE OF A RIGHT-OF-WAY DEED, RECORDED AT BOOK 358, PAGE 172, S00°18'29"E, A TOTAL DISTANCE OF 645.47 FEET TO THE SOUTHWEST CORNER OF SAID RIGHT-OF-WAY DEED AND THE SOUTHWEST CORNER OF SAID ANNEXATION MAP AN-82-87 AND BEING A POINT ON THE WESTERLY RIGHT-OF-WAY OF STATE HIGHWAY 85 AND BEING A POINT ON THE WESTERLY LINE OF ANNEXATION BOUNDARY MAP AN-144-98;

THENCE WITH THE SOUTHERLY LINE OF SAID RIGHT-OF-WAY DEED, RECORDED AT BOOK 358, PAGE 172 AND BEING THE SOUTH LINE OF SAID ANNEXATION BOUNDARY MAP AN-82-87, AND BEING THE WESTERLY RIGHT-OF-WAY OF STATE HIGHWAY 85 AND BEING A POINT ON THE WESTERLY LINE OF ANNEXATION BOUNDARY MAP AN-144-98, N30°44'00"E, A TOTAL DISTANCE OF 193.93 FEET;

THENCE WITH THE EAST LINE OF SAID ANNEXATION BOUNDARY MAP AN-82-87, AND WITH THE EAST LINE OF SAID RIGHT-OF-WAY DEED, RECORDED AT BOOK 358, PAGE 172, N00°18'29"W, A TOTAL DISTANCE OF 480.00 FEET;

THENCE, S89°18'07"W, A DISTANCE OF 100.00 FEET TO THE POINT OF BEGINNING;
SAID PARCEL CONTAINS 1.292 ACRES (56,273 SQUARE FEET), MORE OR LESS.

CANAM
PLANNED UNIT DEVELOPMENT ZONE DOCUMENT
COMMERCE CITY, COLORADO

OWNER:
Reisbeck Subdivision LLC
2677 S. Clayton Street
Denver, CO 80210

DATE:

10/14/20 PUDZD 01
03/29/21 PUDZD 02
06/01/21 PUDZD 03
08/17/21 PUDZD 04

SHEET TITLE:

COVER
SHEET

SHEET NUMBER:

2 OF 10

CANAM PUD ZONE DOCUMENT

A PARCEL OF LAND LOCATED WITHIN SECTION 10, TOWNSHIP 2 SOUTH, RANGE 67 WEST OF THE SIXTH PRINCIPAL MERIDIAN, CITY OF COMMERCE CITY,
COUNTY OF ADAMS, STATE OF COLORADO

PROJECT SUMMARY

Project Area: Approximately 36 acres.

Existing Comprehensive Plan Designation: Residential-High & Local Commercial Center

Existing Zoning Use: Agricultural

Project Description: The CanAm PUD Zone Document describes the permitted land uses and development standards for this property located on the southwest corner of US Highway 85 and East 112th Avenue. CanAm PUD is envisioned as a traditional neighborhood with mixed-use, commercial and residential uses. Incorporated into the neighborhood will be a local commercial and mixed use area, and a variety of residential home types. The community will have convenient access to major transportation corridors in the area.

The purpose of this CanAm PUD is to encourage the development of this site as a cohesive development, and to allow greater flexibility in design to meet market demand.

This PUD Zone Document is also intended to protect and promote the public health, safety and welfare of the future residents of Commerce City, while establishing compatibility with nearby land uses.

GENERAL NOTES

1. Access is preliminary and subject to final approval by Public Works.
2. In the event of any conflict between a standard stated in this CanAm PUD and the Commerce City Land Development Code, then this CanAm PUD will apply. If the CanAm PUD Zone Document does not state a relevant standard, then the Commerce City Land Development Code, as amended, shall apply.
3. Graphics and images shown are representational only. Final locations, quantities and design of elements to be determined during final plat submittal.

DESIGN GUIDELINES

In order to promote and establish a unified theme for CanAm PUD, the Design Standards established in the City of Commerce City Land Development Code shall be followed, as well as this PUD Zone Document. Any additional Design Guidelines will be prepared for use by a Homeowners' Association and/or Metropolitan District. Design Guidelines shall encourage compatible and complimentary character to the Belle Creek Neighborhood to the south. The residential land use designation of patio homes (outlined in the PUD Zoning Land Use Chart on sheet 3) envisioned for Planning Areas B and D will offer a suitable transition from the single-family detached homes of Belle Creek to the south, to the more dense residential and commercial uses of Planning Areas A and C, while still allowing for density, as noted in the City's Vision Plan. Appropriate transitions of character will occur between residential and other adjacent land uses to create a cohesive feel to the public ROW and providing buffering where required. Complimentary design character may be achieved through built amenities and elements such as fencing, columns, signage, monumentation, walls, furnishings and lighting. Landscape materials will be a unifying element along the streetscape through consistent use of tree lawns, similar plant and tree palettes and mulch/ground cover materials. The color palette, forms and materials for built elements shall compliment those found in Belle Creek, while allowing for context appropriate variation across multi-family and commercial areas. Where CanAm transitions into the Belle Creek neighborhood, site features, landscape, and architecture shall reflect a more traditional character; include a warm and earth-toned color palette; and use similar materials such as CMU block and stone veneer.

NEIGHBORHOOD CHARACTER

As a jewel along the Highway 85 corridor, the CanAm PUD will integrate commerce and community. Design features will be focused on the interior of the neighborhood to promote internal connectivity and a sense of place. Design character for architecture, site and landscape features throughout the neighborhood will blend contemporary forms with raw and natural materials representing the forward thinking mix of land uses within the neighborhood while respecting the region's history in agriculture, trading and commerce. Use of medium to dark colored stone veneer in architecture and site features adds both contemporary colors and natural texture. Natural wood is integrated through fencing, signage and landscape areas. The plant palette includes locally appropriate, water conscious materials and reflects the neighborhood's proximity to the South Platte River riparian corridor. Stone Veneer columns will be used throughout the neighborhood architecture and site elements creating a common thread that ties the overall design together through high quality materials. Examples where stone veneer may be applied across site elements include: signage and entry monumentation; columns for fencing, gates or walls and light pole bases. Use of similar stone veneer may also be incorporated into pilasters of commercial buildings, multi-family residential facades, and facades of townhomes.

Community design elements and standards play an important role in a well-planned neighborhood and should be viewed as a cohesive package, where each element has a particular function and purpose. As the CanAm PUD is developed over time, the developer will assess all the functions and purposes that should be accommodated within the public space of the neighborhood, and then implement the appropriate elements and standards to allow those functions to occur in a safe and effective manner. Staying within a general neighborhood planning and design theme helps create an identifiable and cohesive neighborhood over time. Community Design Elements and Standards shall be defined with each PUD Permit, and will include landscape, site furnishings, lighting, fencing, walls and other elements that support the overall design character and promote a sense of community.

COMMUNITY DESIGN ELEMENTS

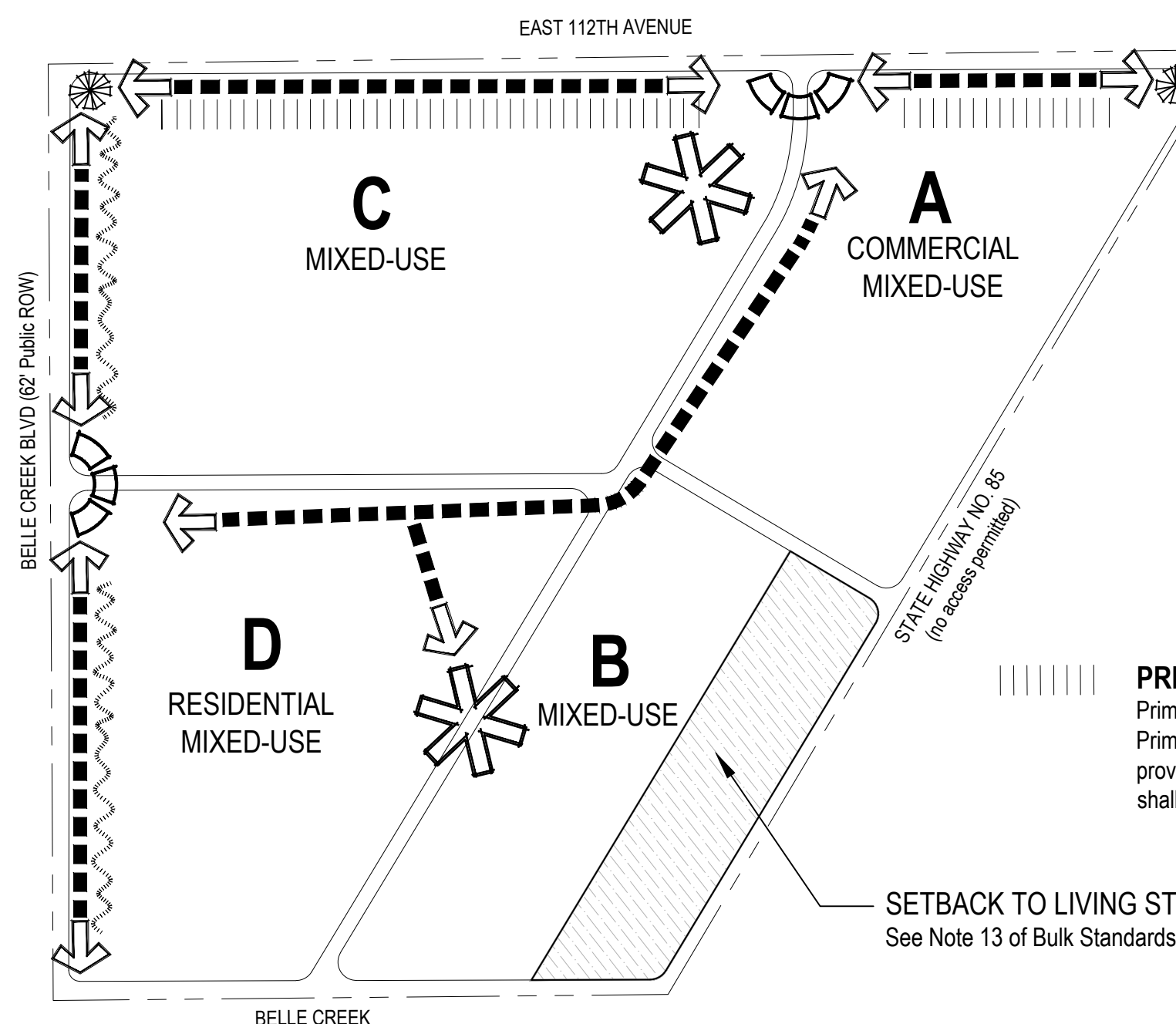

POTENTIAL PARK/NEIGHBORHOOD FOCAL POINT

The Potential Park/Neighborhood Focal Point will serve as a visual landmark and central gathering space for the neighborhood. The space shall include enhanced landscape, seating and locations for potential public art displays. In this central location, the focal point shall connect varied land uses on the site and help unify the overall neighborhood character. Specific layout, design and size will be determined with a PUD Permit. This feature may include street improvements, plaza space, a round-about, pocket park, and other elements that are functionally appropriate for this neighborhood. Location shown is not specific, is flexible and may be shared across multiple Planning Area or may be incorporated fully into one Planning Area. The amount of park space shall comply with the established requirement for parks outlined in the City of Commerce City Land Development Code.



PRIMARY ENTRY

The Primary Entries will serve as the primary gateway into the community. Primary neighborhood monumentation, signage and signature landscape will be integrated into the entry, drawing interest from the perimeter roadways and communicating the neighborhood character.



ENTRY MARKER

The Entry Markers will support primary entries through signage and signature elements on a smaller scale, further conveying the neighborhood identity. Entry Markers will support wayfinding within internal corridors and secondary streets on the neighborhood perimeter roadways and communicating the neighborhood character.



PRIMARY EDGE

Primary Edges are where the neighborhood will convey its image within Commerce City. Primary Edges will include signature landscape, fencing, buffers and other features that provide a unified appearance along perimeter roadways. Features along Primary Edges shall be of a scale to provide a visual impact on Highways and Arterial Streets.



SETBACK TO LIVING STRUCTURES AREA

SETBACK TO LIVING STRUCTURES (150' MIN.)
See Note 13 of Bulk Standards Notes on Sheet 4.



PROPOSED TRAILS

Sidewalk and trail connections will facilitate safe pedestrian circulation throughout CanAm as well as to local destinations such as community parks. Sidewalks will connect with the larger network of trails adjacent to CanAm.



SECONDARY EDGE

Secondary Edges will support Primary Edges in conveying the neighborhood identity. Secondary Edges will include signature landscape, fencing, buffers and other features that provide a unified appearance along secondary perimeter roadways. Features along Secondary Edges shall be of a scale appropriate to local roadways.

FENCING

Fencing shall be incorporated to contain or screen areas (where needed), promote wayfinding and convey the community character and image. Materials balance traditional and contemporary character. Column materials may include stone veneer, CMU block and cast concrete. Fencing design shall be based on a horizontal rail, allowing a range of fencing types and combinations while providing a cohesive aesthetic. Rails and posts may include wood, metal or vinyl compatible with adjacent land use. Screen fencing shall be incorporated to screen off and on-site areas requiring an visual buffer. Open rail fence will be used along perimeter roadways and areas that promote connectivity between spaces as appropriate. Where determined necessary, columns may be incorporated at key visual areas at entries and along perimeter roadways. Fence heights will likely vary depending on fence type and context.



Example fence types and variation shown above, to include: wood rail and posts and stone veneer or CMU columns. Strand wire can also be incorporated with open rail where appropriate. Fence may be painted or solid color as appropriate for residential areas.

SITE FURNISHINGS

Site furnishings shall support the overall neighborhood character and will compliment landscape, fencing and lighting styles. Commercial areas shall include highly durable finishes. Typical furnishings will include benches, trash and recycling receptacles, bike racks, bollards, picnic tables and pet stations. The images below represent potential styles with appropriate materials and character. Final selections will be determined during the PUD permit process.



LIGHTING

Site lighting will include common fixtures along connectivity corridors and district specific lighting compatible with specific land uses. Lighting design shall be complimentary to site furnishings and other design elements. Lighting shall meet all local requirements for light shielding. Bollard lighting may be used to light pathways or gathering spaces.

LANDSCAPE CHARACTER

The landscape character of the neighborhood will be a unifying element along corridors, buffers and within public spaces. Geometric forms and massings intersected by flowing arcs will be used to provide structure to the landscape. Plant massings will be scaled to be impactful and sized appropriately for internal and external streetscapes. The plant palette shall draw from the City approved list, using water conscious and maintainable regionally appropriate species. Signature plants will provide an anchor for landscape consistency, and will be determined at PUD Permit.

CANAM
PLANNED UNIT DEVELOPMENT ZONE DOCUMENT
COMMERCE CITY, COLORADO

OWNER:
Rebeck Subdivision LLC
2677 S. Clayton Street
Denver, CO 80210

DATE:
10/14/20 PUDZD 01
03/29/21 PUDZD 02
06/01/21 PUDZD 03
08/17/21 PUDZD 04

SHEET TITLE:
PROJECT
INTENT
SHEET NUMBER:
3 OF 10

CHECKED BY: JN / GB
FILENAME: PUD-PERMIT

CANAM PUD ZONE DOCUMENT

A PARCEL OF LAND LOCATED WITHIN SECTION 10, TOWNSHIP 2 SOUTH, RANGE 67 WEST OF THE SIXTH PRINCIPAL MERIDIAN, CITY OF COMMERCE CITY,
COUNTY OF ADAMS, STATE OF COLORADO

PUD ZONING LAND USE CHART

PLANNING AREA	USE	DESCRIPTION OF USES (1)	ACRES	% OF OVERALL DEVELOPMENT	PERMITTED GROSS DENSITY	MAX. DWELLING UNITS
A	Commercial Mixed-Use	Potentially includes a mix of land uses such as multifamily residential, neighborhood level commercial, retail and office uses.	7.5 AC	19.7%	0.5 FAR Maximum (Non-Residential) / 30 DU/AC Maximum, 8 DU/AC Minimum (Residential)	185 (5)
B	Mixed-Use	Potentially includes a mix of land uses such as Patio Home Type A and Type B, single-family attached (triplex and quadplex), townhomes, multifamily residential, neighborhood level commercial, retail and office uses.	7.1 AC	18.8%	25 DU/AC Maximum, 8 DU/AC Minimum (Residential) / 0.25 FAR Minimum (Non-Residential)***	
C	Mixed-Use	Potentially includes a mix of land uses such as Patio Home Type A and Type B, single-family attached (triplex and quadplex), townhomes, multifamily residential, neighborhood level commercial, retail and office uses.	13.3 AC	35.2%	30 DU/AC Maximum, 8 DU/AC Minimum (Residential) / 0.25 Minimum FAR (Non-Residential)	600 (PAs, B, C & D) (5)
D	Residential Mixed-Use	Potentially includes a mix of land uses such as Patio Home Type A and Type B, single-family attached (triplex and quadplex), townhomes, multifamily residential, neighborhood level commercial, retail and office uses.	10.0 AC	26.3%	25 DU/AC Maximum, 8 DU/AC Minimum (Residential) / 0.25 FAR Minimum (Non-Residential)***	
Parks and Open Space		Parks, Open Space, and Trails*	B, C and D only.	3.0%**		
Total Land Area			37.9 AC			

*Location and configuration of parks will be determined during future PUD Permit approvals. The percentage of parks and open space noted above reflect requirements defined in the City of Commerce City Land Development Code. Trails depicted are conceptual. Location and configuration of trails will be determined during future PUD Permit approvals.
 **Open space requirements are separate for multi-family uses as defined in Note 5 of the General Notes on Sheet 4.
 ***When a residential use is proposed in PA-B and the 150 ft. minimum setback to living structures is applied, and PA-B and PA-D are addressed in a single PUD Permit, then the combined area of PA-B and PA-D shall have a minimum density of 8 DU/AC.

GENERAL NOTES

- "Description of Uses" outlines the primary intended land use(s) for the subject Planning Area. However, additional land uses may be allowed per the "Table of Allowed Land Uses" on sheet 6 and subject to Community Development Director approval.
- The Planning Area acreage and shapes may be administratively varied up to 15% without a PUD Zone Document Amendment so long as shapes, locations of land uses, and compatibility generally remain consistent.
- Drainage facilities for this CanAm PUD will be served by detention ponds located within this PUD Zone Document boundary. Reference the CanAm Preliminary Drainage Report for more information.
- Access points and road classifications shown are conceptual and subject to change during the PUD Permit approval process. Final access points and road classifications will be determined by traffic analysis(es) at that time.
- Maximum residential units allowed are defined in the "Max. Dwelling Units" column of this chart. As the property within this PUD Zone Document develops over time, residential units will be defined at the PUD Permit level of approvals, but shall not exceed 185 units in Planning Area A, and 600 units in Planning Areas B, C & D combined.
- Specific land uses shall be defined with future PUD Permit applications.
- Drainage and roadway improvements will be proposed with future PUD Permit applications.
- Location and configuration of trails will be determined during future PUD Permit approvals.

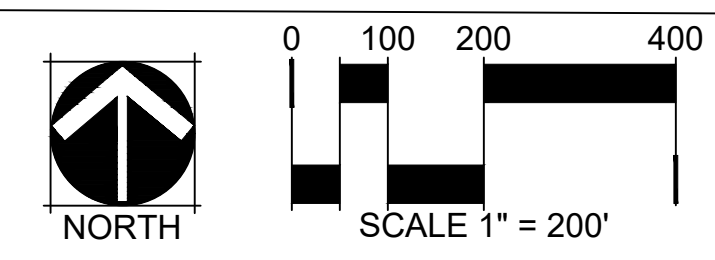
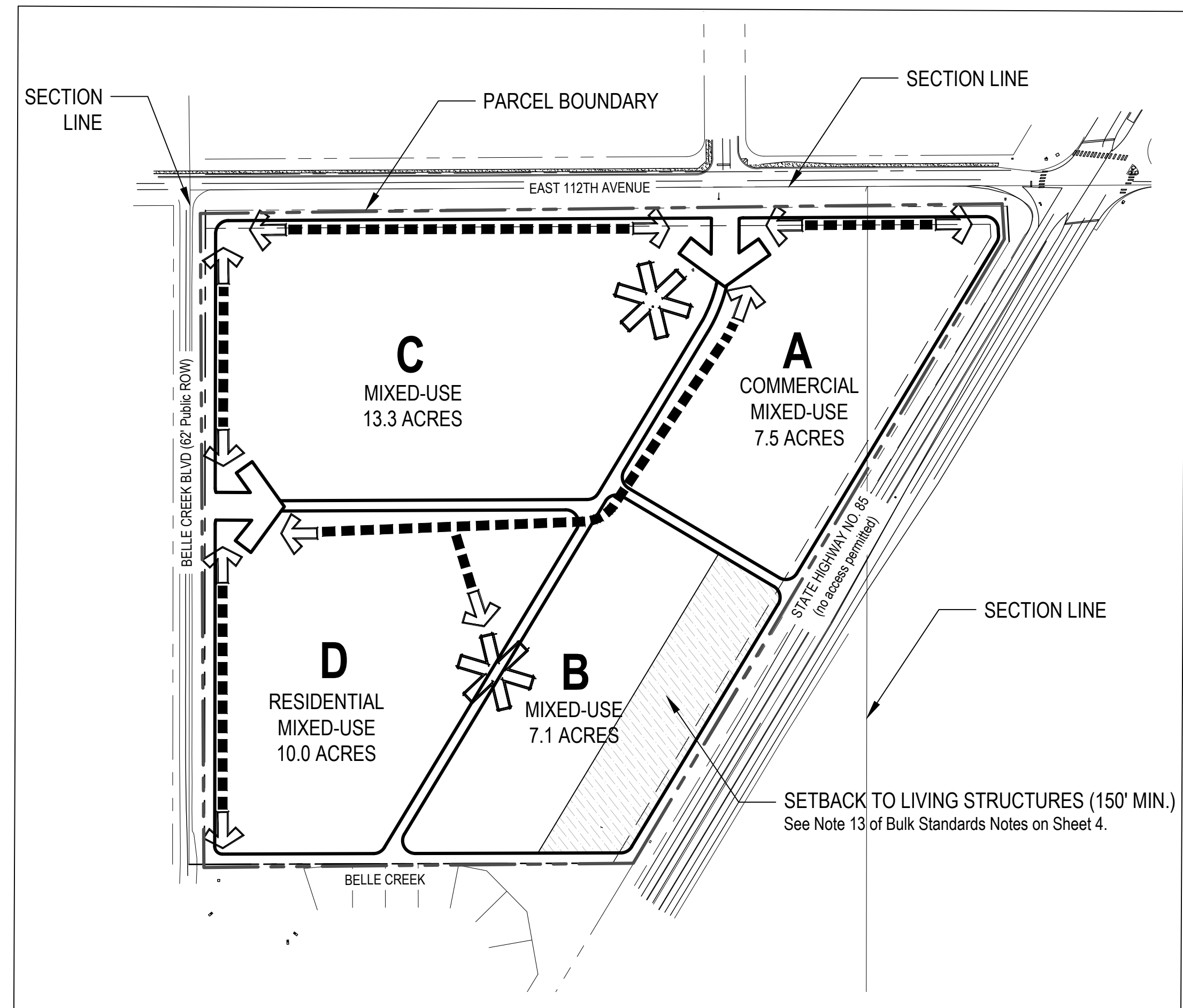

LEGEND

- POTENTIAL PARK/COMMUNITY FOCAL POINT
- PROPOSED TRAILS
- SETBACK TO LIVING STRUCTURES AREA
- POTENTIAL ACCESS POINTS

CANAM
PLANNED UNIT DEVELOPMENT ZONE DOCUMENT
COMMERCE CITY, COLORADO

OWNER:
Reisbeck Subdivision LLC
2677 S. Clayton Street
Denver, CO 80210

DATE:
10/14/20 PUDZD 01
03/29/21 PUDZD 02
06/01/21 PUDZD 03
08/17/21 PUDZD 04

SHEET TITLE:
PUD ZONING
MAP
SHEET NUMBER:
4 OF 10

CHECKED BY: JN/GB
FILENAME: F27UD-PERMIT

CANAM PUD ZONE DOCUMENT

A PARCEL OF LAND LOCATED WITHIN SECTION 10, TOWNSHIP 2 SOUTH, RANGE 67 WEST OF THE SIXTH PRINCIPAL MERIDIAN, CITY OF COMMERCE CITY,
COUNTY OF ADAMS, STATE OF COLORADO

BULK STANDARDS

USES	LOT SIZE (MIN.)	LOT WIDTH (MIN.) (2)	MIN. GROSS FLOOR AREA (11)	SETBACK (MIN.) FOR ALL STRUCTURES ADJACENT TO: (5, 6, 8)		SETBACK (MIN.) FOR ALL LIVING STRUCTURES ADJACENT TO: HIGHWAY 85	FRONT YARD SETBACK (MIN.) (5, 6, 8, 9)	SIDE YARD SETBACK (MIN.) (1, 5, 6, 8, 9)	REAR YARD SETBACK (MIN.) (5, 6, 8, 9)	BUILDING HEIGHT (MAX.) (4)
				ARTERIAL	COLLECTOR					
Patio Homes (12) (15)	N/A	N/A	1-Bedroom: 550 sf 2-Bedroom: 700 sf 3-Bedroom: 850 sf 4-Bedroom: 1,000 sf	25'	20'	150' (13)	SETBACK	SETBACK	SETBACK	35', 40' (16)
							20' to living (public local street)	20' to living (public local street)	5' to living (private street)	
							5' to living (private street) (4' to living with 1' encroachments. See Note 5 for list of encroachments.)	5' side corner to living (private street)	15' to living (property line)	
								15' to living (property line)	0' common wall	
							BUILDING SEPARATION	BUILDING SEPARATION	BUILDING SEPARATION	
			10' (8' with encroachments. See Note 5 for list of encroachments.)	10'	10'					
Townhomes	1,800 SF	20 (interior unit)	800 SF (1-STORY)/ 1,250 SF (2-STORY)	25' (7)	20' (7)	150'	6' to porch 10' to living 20' to garage	5' exterior wall 0' common wall 10' side corner (3)	15' (front loaded) 6' (rear loaded- no parking) 20' (parking allowed)	40'
Multi-family Residential	N/A	N/A	N/A	25' (7)	20' (7)	N/A	15' (7, 10)	15' (20' min. building separation) (10)	15' (10)	60'
Non-Residential Uses	N/A	30'	N/A	25'	20' (7)	N/A (14)	10' (7, 10)	0' (20' min. building separation) (10)	15' (10)	60'

The following parking standards shall apply to the CanAm PUD Zone Document area. Land uses not specifically listed in the table below shall reflect minimums outlined in the current code. Off-street parking includes garage spaces and driveways. Parking standards for all uses may be met using any combination of covered and uncovered parking.

OFF STREET PARKING REQUIREMENTS

TABLE VII-3 OFF-STREET PARKING REQUIREMENTS		
RESIDENTIAL USES		
HOUSEHOLD LIVING	MULTI-FAMILY DWELLING, PATIO HOMES	1 space per 1 bedroom; 1.5 spaces per 2 bedroom; 2 spaces per 3+ bedroom; +10% of total required spaces for visitor parking
	SINGLE-FAMILY ATTACHED DWELLINGS	2 spaces / dwelling unit
NON-RESIDENTIAL		Reference Commerce City Land Development Code

BULK STANDARDS TABLE NOTES:

- 0' lot line configurations are allowed. When 0' lot line configurations are permitted; detached garages may also utilize a 0' setback. All structures must meet separation and code requirements as well as minimum standards for architecture.
- Minimum lot width shall be measured at the front lot line. Lot width may be measured at the front setback when lots are located along a curve.
- Side setbacks may be reduced to no less than 3' as measured from the finished material of the exterior wall to the property line (unless using a 0' lot line configuration - see above).
- Building height excludes parapets and other architectural treatments that screen rooftop mechanical equipment from view. These items are subject to height limitations as deemed appropriate during the development review process.
- Encroachments may include bay windows, window wells, cantilevers, chimneys, exterior posts/columns, solar panels, mechanical equipment, light fixtures, balconies, stairs, eaves, roof over hangs and other similar architectural features are allowed to extend outward from the principal structure in front, side and rear yards. In no instance may an encroachment cross the property line or be located less than six-feet from the finished material of the encroachment to the adjacent property. Side-loaded garages and non-livable structures, such as covered porches and courtyards can encroach into a setback up to 5' provided the encroachment is not within the public right-of-way or transportation and utility easements.
- Setbacks shall be measured from public right-of-way to the foundation. 10' side yard setback for corner lots shall only apply to lots abutting a public right of way. Lots siding onto private streets, alleys, open space areas, or other similar uses shall use the 5' side yard setback standards. The driveway length shall be at least 20' from the back of the public sidewalk.
- Multi-family and Commercial development may utilize a 0' setback to public and private streets when used in all planning areas to promote an urban edge/streetscape.
- Roof overhangs are permitted with a maximum encroachment of 2' into the building setback.
- Window wells are permitted to encroach into setbacks up to 3', as long as adequate drainage is accommodated.
- For Multi-family Residential and Non-Residential uses, setbacks shall be measured from each property line.
- Minimum gross floor area does not include garage or basement square footage.
- As patio homes will be located on a common lot (See Definitions on Sheet 6), they will not be subject to minimum lot size, minimum lot width, and/or minimum setbacks from other lots. Setbacks will be administered as minimum building separation using minimum front, side, and rear yard dimensions. Parking standards for these types of homes may be met using a combination of attached garages, detached garages, other covered parking spaces, and/or non-covered parking spaces.
- Within PA-B, no living structures are permitted within this setback. However, all other allowed uses in PA-B are allowed within this setback. Other non-living structures and improvements associated with residential uses are permitted including the following uses: detached garages, covered and uncovered parking, drive aisles, streets, detention and drainage facilities, parks, open space, trails, clubhouses, pools, utilities, and/or other similar uses.
- See the Convenience and Fuel Sales Uses Setbacks from Highway 85 Chart for specific setbacks in the PUD Zone Document.
- Patio Home bulk standards listed above shall apply to Patio Homes Type A and Type B.
- A maximum building height of 35 ft is allowed in PA-B & D for Patio Homes. A maximum building height of 40 ft is allowed in PA-C for Patio Homes.

GENERAL NOTES:

- No direct vehicular access to arterial or collector street for individual residences is permitted.
- The tread of the first entry step may be located immediately adjacent to public sidewalk.
- Shared driveways/driveway easements are permitted for all uses per then current code requirements.
- Accessory structures include all structures located within the parcel in which the use is incidental to the use of the principal structure.
- Multi-family uses shall be subject to a Minimum Open Space requirement of 15 percent of gross lot area. Open space may include common areas, recreational facilities, community gardens, landscape areas or any other open space areas.

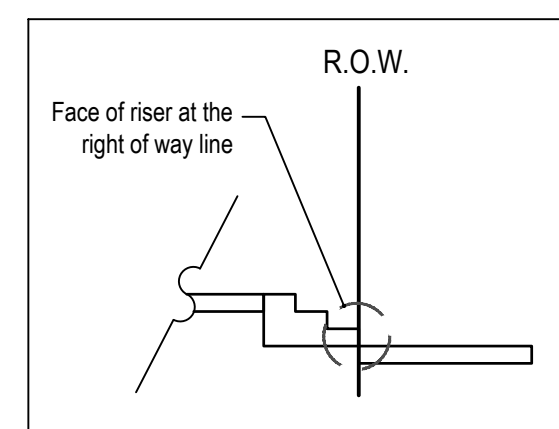

TREAD RISER AT R.O.W.
(See General Note 2)

CONVENIENCE STORE / FUEL SALES USES FROM HIGHWAY 85 SETBACKS CHART (PA-A)

STRUCTURE/SITE ELEMENT	SETBACK
Commercial Building	90 feet (min.)
Parking	15 feet (min.)
Drive Aisle	20 feet (min.)
Fuel Pumps	40 feet (min.)
Fuel Island Canopy	25 feet (min.)

CANAM
PLANNED UNIT DEVELOPMENT ZONE DOCUMENT
COMMERCE CITY, COLORADO

OWNER:
Reisbeck Subdivision LLC
2677 S. Clayton Street
Denver, CO 80210

DATE:

10/14/20 PUDZD 01
03/29/21 PUDZD 02
06/01/21 PUDZD 03
08/17/21 PUDZD 04

SHEET TITLE:
LAND USE
STANDARDS
SHEET NUMBER:
5 OF 10

CANAM PUD ZONE DOCUMENT

A PARCEL OF LAND LOCATED WITHIN SECTION 10, TOWNSHIP 2 SOUTH, RANGE 67 WEST OF THE SIXTH PRINCIPAL MERIDIAN, CITY OF COMMERCE CITY,
COUNTY OF ADAMS, STATE OF COLORADO

TOWNHOME LOT TYPICALS

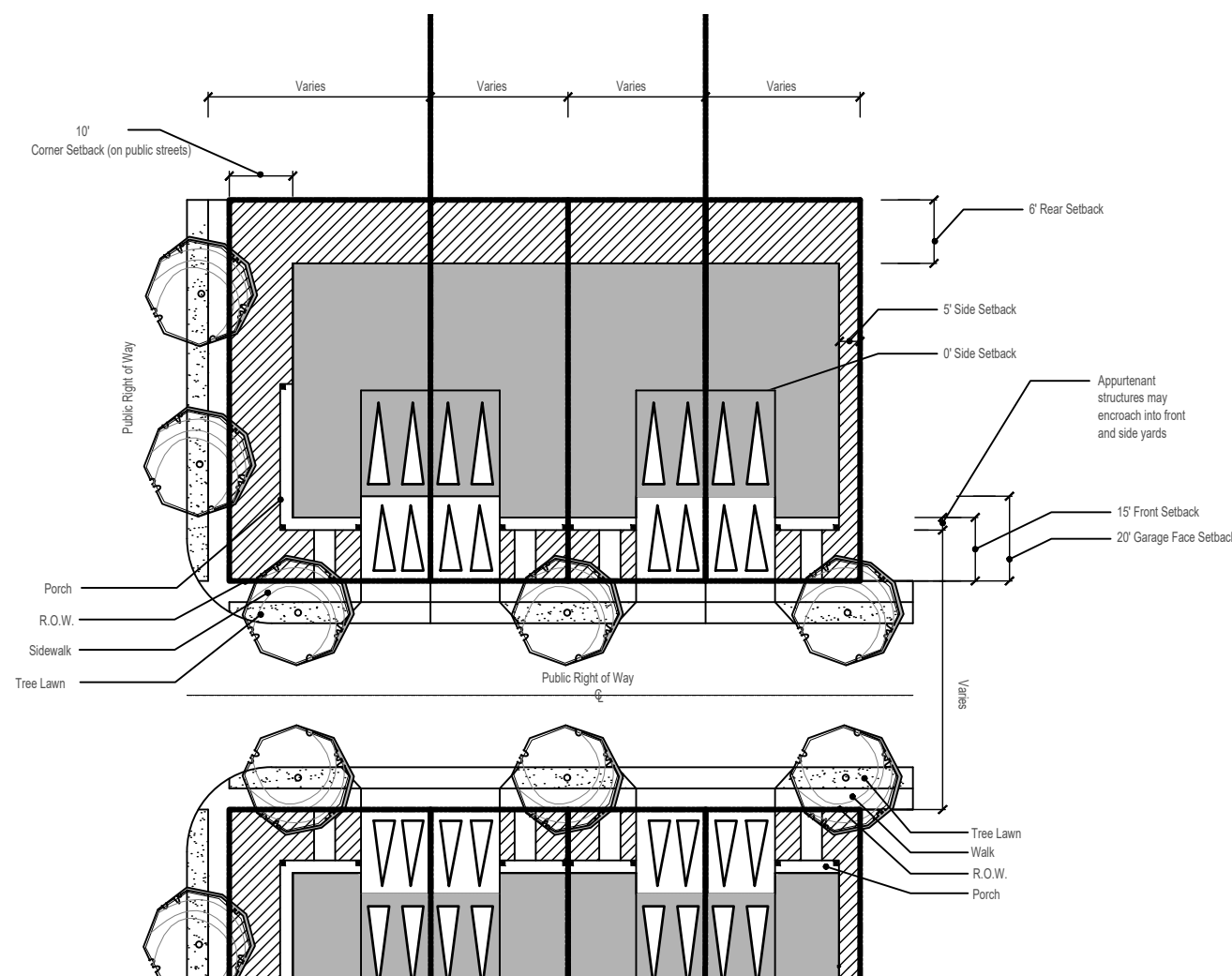

TOWNHOME - FRONT LOAD - TYPICAL
CONCEPTUAL DRAWING SUBJECT TO CHANGE

NOT TO SCALE

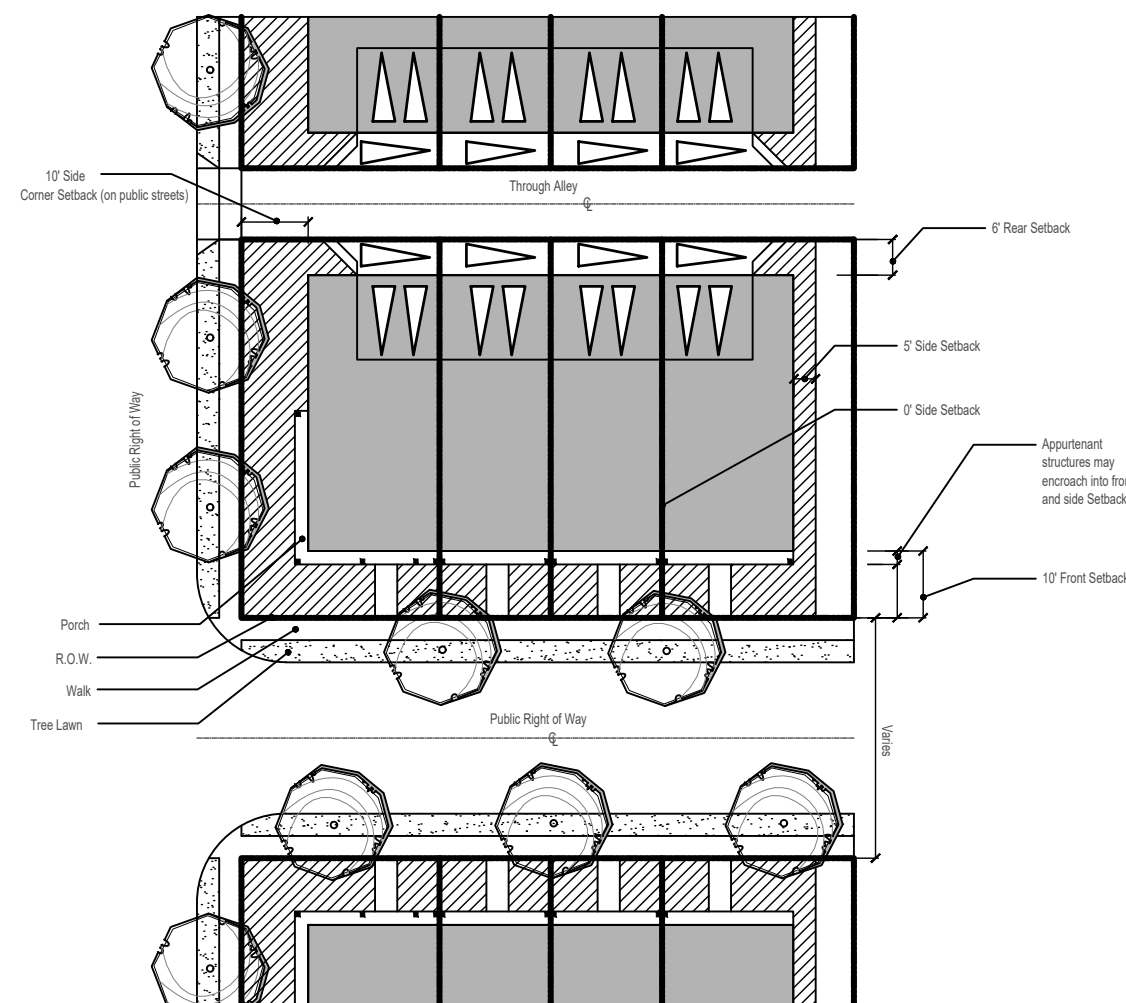

TOWNHOME - REAR LOAD - TYPICAL
CONCEPTUAL DRAWING SUBJECT TO CHANGE

NOT TO SCALE

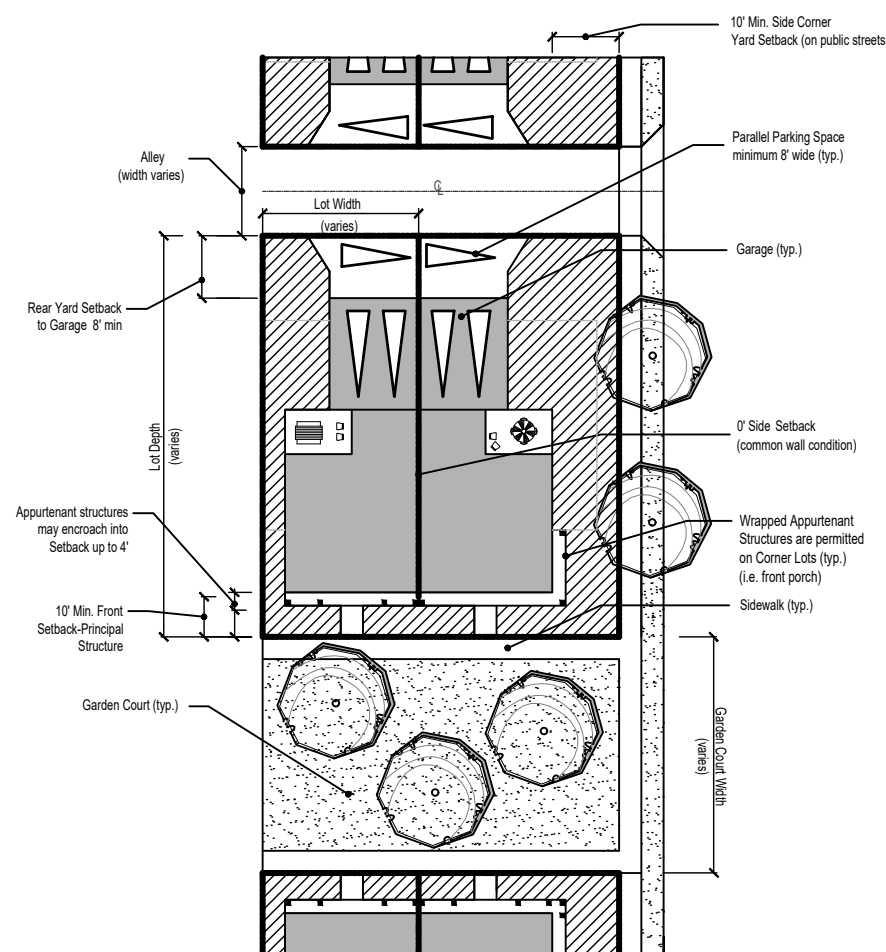

TOWNHOME - REAR LOAD - GREEN COURT - TYPICAL
CONCEPTUAL DRAWING SUBJECT TO CHANGE

NOT TO SCALE

PATIO HOME LOT TYPICALS

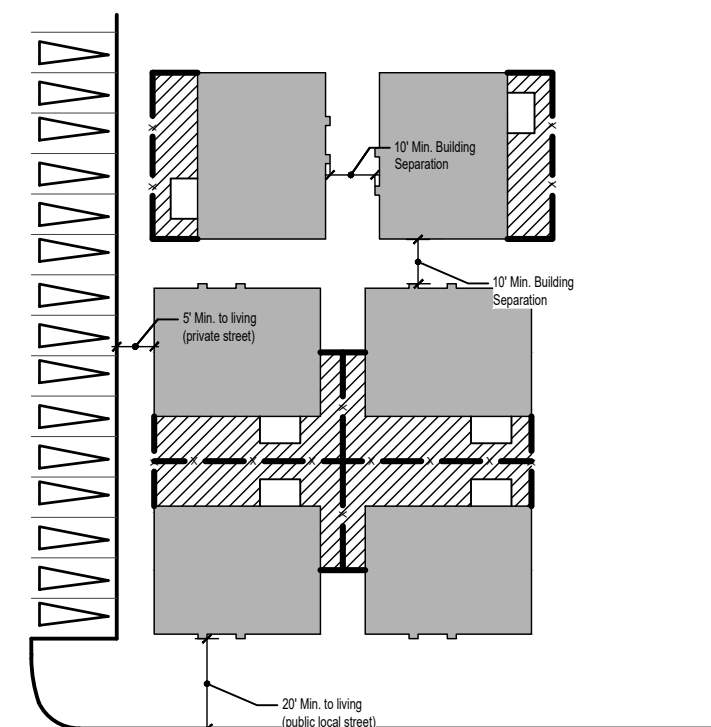

PATIO HOME - TYPICAL
CONCEPTUAL DRAWING SUBJECT TO CHANGE

NOT TO SCALE

LOT TYPICAL NOTES

1. Typical layouts reflect bulk standards conveyed on sheet 4 of this PUD Zone Document and represent multiple, but not all configurations for each lot component depicted. Width and dimensions may change as appropriate provided design is consistent with the bulk standards listed on sheet four.
2. Parallel parking is permitted for rear-loaded townhome and duplex lots a minimum of 25' wide.
3. These lot typical diagrams for Townhome residential uses apply to buildings with two or more attached units.

CANAM
PLANNED UNIT DEVELOPMENT ZONE DOCUMENT
COMMERCE CITY, COLORADO

OWNER:
Reisbeck Subdivision LLC
2677 S. Clayton Street
Denver, CO 80210

DATE:
10/14/20 PUDZD 01
03/29/21 PUDZD 02
06/01/21 PUDZD 03
08/17/21 PUDZD 04

SHEET TITLE:
LOT
TYPICALS
SHEET NUMBER:
6 OF 10

CANAM PUD ZONE DOCUMENT

A PARCEL OF LAND LOCATED WITHIN SECTION 10, TOWNSHIP 2 SOUTH, RANGE 67 WEST OF THE SIXTH PRINCIPAL MERIDIAN, CITY OF COMMERCE CITY,
COUNTY OF ADAMS, STATE OF COLORADO

TABLE OF ALLOWED USES (BY PLANNING AREA)

USE CLASSIFICATION	SPECIFIC USE TYPE	PLANNING AREA			
		A	B	C	D
AGRICULTURAL USES					
Horticulture & Nurseries	Community garden	R	R	R	C
	Greenhouse/nursery/tree production (with no outdoor storage)	R	R	R	C
COMMERCIAL USES					
Animal Services	Animal boarding (indoor/outdoor kennels) and training	R	R	C	
	Doggie day care centers	R	R	C	
	Veterinary offices or clinics	R	R	C	
Antennas	Antennas for commercial/industrial use accessory to principal use	R	R		
	Antenna and support structure for amateur radio communications	R	R		
	Radio or television broadcasting offices	R	R		
Building Materials & Services (Retail)	All other similar uses (plumbing, electrical, lumber & building equipment-without outdoor storage)	R	R		
	Bar, tavern, night club	R	R	R	
Eating and Drinking Establishments	Brewpub	R	R	R	
	Catering services	R	R		
	Restaurant with drive-thru/up	R	R		
	Restaurant without drive-thru/up	R	R	R	
	Tasting Room	R	R	R	
Financial Institutions	Bank or financial institution	R	R	R	
	Convenience store/grocery store (< 10,000 sf)	R	R	R	
Food and Beverage Sales	Grocery store (> 5,000 sf and < 40,000 sf)	R	R	R	
	Liquor store	R	R	R	
	All other similar uses (e.g., delicatessen, retail bakery, specialty food market, coffee shop)	R	R	R	
	Fuel sales with no vehicle repair	R			
Fuel Sales (see Allowed Use Note 1)	Fuel sales with minor vehicle repair	R			
	Natural gas fuel sales	R			
	Natural gas fuel sales for trucks	R			
	Diesel fuel sales for trucks	R			
	Funeral and Interment Services	Funeral home	R	R	
Office	Business or professional (including medical/dental office/clinics)	R	R	R	R
	Courier services	R	R	R	
	Massage therapy office/clinics	R	R	R	
Personal Services	Instructional services, studios	R	R	R	R
	Bingo establishments/social gaming outlet/performance centers	R	R		
Recreation or Amusement Facilities, Private	Bowling, billiards, movie theaters & similar uses	R	R		
	Health clubs	R	R	R	R
	Outdoor recreation	R	R		
Repair Services (Not Including Vehicles)	Furniture or major household appliance repair	R	R		
Retail Establishments	Retail business store (< 25,000 square feet)	R	R	R	C
	Retail business store (> 25,000 square feet and < 40,000 sf)	R	R	R	
	Tattoo parlor	R	R		
	Thrift/consignment store	R	R		
Vehicle/Equipment Sales and Services	Automobile rentals	R			
	Automobile washing facility	R			
	Tire shop	R			
	Vehicle repair, minor	R			
Visitor Accommodations	Bed and breakfast establishments	R	R	C	C
	Hotel or motel lodging establishments	R	R	R	
Manufacturing, Food	Brewery	R	R		
	Distillery	R	R		
	Microbrewery	R	R		
	Micro-winery	R	R		
OFFICE FLEX					
Office Flex	Office Flex	R	R	R	R

LEGEND

R = Allowed by Right
C = Conditional Use

DEFINITIONS

- Arts and Cultural Uses shall mean a space providing for creation, display, performance, or enjoyment of heritage, history, or the arts. This use includes but is not limited to: museums, performance space, artist's studios, galleries, interpretive sites, and independent theaters.
- Artisan/Handcrafted Manufacturing shall mean the shared or individual use of hand-tool, mechanical tools and electronic tools for the manufacturer of finished products or parts including design, processing, fabrication, assembly, treatment, and packaging of products; as well as the incidental storage, sales and distribution of such products. Typical artisan manufacturing uses include, but are not limited to: electronic goods, food and bakery products, non-alcoholic beverages, printmaking, household appliances, leather products, jewelry and clothing/apparel, metal work, furniture, glass or ceramic production.
- Patio Homes Type A shall mean a building or group of buildings located on a common lot, in which dwelling units are designated for lease or rent as a residence. Low Density Patio Homes may take the form of single-family detached or paired housing products.
- Patio Homes Type B shall mean a building or group of buildings located on a common lot, in which dwelling units are designated for lease or rent as a residence. High Density Patio Homes may take the form of triplex or higher multiple unit buildings.

USE CLASSIFICATION	SPECIFIC USE TYPE	PLANNING AREA			
		A	B	C	D
INDUSTRIAL USES					
Artisan/Handcrafted Manufacturing	Artisan/handcrafted manufacturing	R	R		
	Manufacturing, Oil and Gas	C	C	C	C
Research and Development Services	Scientific R & D services	R	R		
	Testing laboratories, non-medical	R	R		
PUBLIC, INSTITUTIONAL & CIVIC USES					
Ambulance Service	Garage and office for ambulance service	R	R		
Arts and Cultural Uses	Arts and cultural uses	R	R	R	
Clubs and Lodges	Private lodge or club	R	R	R	
	Gun club (indoor)	R	R		
Community Services	Events center (< 15,000 sf)	R	R	R	
	Events center (> 15,000 sf and < 40,000 sf)	R	R	R	
Day Care Facilities, Adult or Child	Child care center	R	R	R	R
	Adult day care center	R	R	R	R
	Outpatient surgical centers	R	R	R	
Public Lands, Parks, and Buildings	Library	R	R	R	R
	Public administrative office or service building	R	R	R	
	Public park or recreational facilities	R	R	R	R
Religious Institutions	Police or fire station	R	R	R	
	Church or religious institution	R	R	R	R
Educational Facilities	Elementary and secondary education schools	R	R	R	R
	Private business, trade, and vocation schools	R	R	R	
	Post secondary colleges and universities	R	R	R	
	Schools of special instruction	R	R	R	
Transportation Facilities (See Allowed Use Note 4)	Parking garage	R			
	Public parking lot	R			
Utilities	Public utility office	R	R	R	
RESIDENTIAL USES					
Household Living	Foster care home	R	R	R	
	Multi-family dwelling	R	R	R	R
	Patio Homes Type A		R	R	R
	Patio Homes Type B		R	R	R
	Single-family attached townhomes		R	R	R
	Boarding or rooming house		R	R	
	Home occupation		R	R	R
Senior Housing	Assisted living facility	R	R	R	R
	Nursing homes	R	R	R	

ALLOWED USE NOTES:

- Fuel sale uses are permitted up to 5 pump islands (2 pumps per island) for standard car fueling and 4 individual bays (consisting of 5 pump islands) for diesel truck fueling. Individual bays allow vehicles to utilize a dispenser to fill tanks on both sides of the vehicle at the same time. Diesel fuel sales for trucks is permitted.
- Grocery/convenience store uses operating on a twenty-four (24) business schedule are allowed in those parcels where such food and beverage sales uses are allowed.
- Commerce City liquor laws and licensing requirements/limitations will apply, as applicable.
- Residential Parking facilities are permitted in PA's B, C, & D.

GENERAL USE NOTES

- The existing agricultural uses on the property (farming, ranching, and agricultural support activities) are allowed to continue in operation and use until such time as development occurs in that parcel requiring removal, such as time of Plat and PUD Permit. At that time the agricultural and existing residential use will be discontinued and removed.
- Unless specifically listed or similar to uses listed within this CanAm PUD Zone Document Table of Allowed Uses by Planning Area, a use shall be considered excluded unless otherwise approved by Community Development Director in accordance with the process in article IV of the Land Development Code.
- Temporary and seasonal outdoor uses, such as farmers markets, outdoor nursery displays, and sidewalk sales, are allowed and all must meet the criteria as outlined within the Commerce City Land Development Code. In the event of any conflict between a standard stated in this CanAm PUD Zone Document and the Commerce City Land Development Code, then this CanAm PUD Zone Document will apply. If the CanAm does not state a relevant standard, then the Commerce City Land Development Code, as amended, shall apply.
- School sites are not anticipated in the CanAm PUD Zone Document area.

CANAM
PLANNED UNIT DEVELOPMENT ZONE DOCUMENT
COMMERCE CITY, COLORADO

OWNER:
Reisbeck Subdivision LLC
2677 S. Clayton Street
Denver, CO 80210

DATE:
10/14/20 PUDZD 01
03/29/21 PUDZD 02
06/01/21 PUDZD 03
08/17/21 PUDZD 04

SHEET TITLE:
ALLOWED USES
SHEET NUMBER:
7 OF 10

CHECKED BY: JN/GB
FILENAME: F210-PUD-PERMIT

CANAM PUD ZONE DOCUMENT

A PARCEL OF LAND LOCATED WITHIN SECTION 10, TOWNSHIP 2 SOUTH, RANGE 67 WEST OF THE SIXTH PRINCIPAL MERIDIAN, CITY OF COMMERCE CITY,
COUNTY OF ADAMS, STATE OF COLORADO

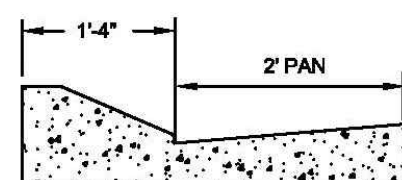

MOUNTABLE CURB DETAIL

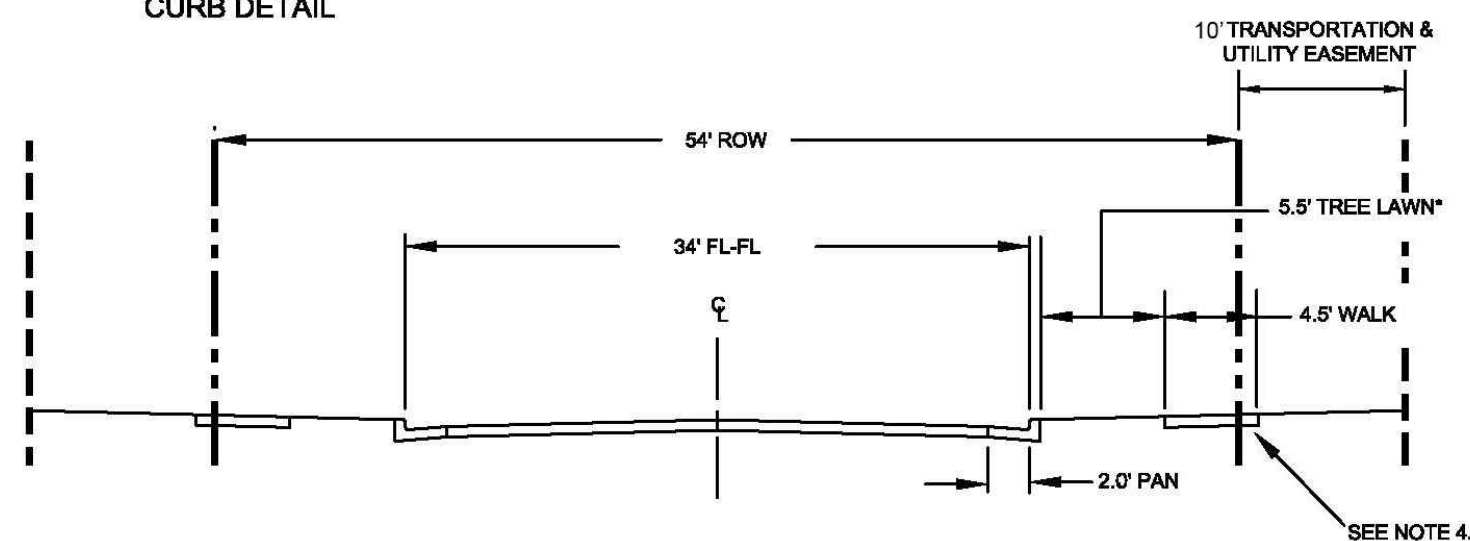

NOTES:

1. STRIPING NOT REQUIRED.
2. ON STREET PARKING ALLOWED BUT NOT PERMITTED WHEN NEEDED FOR FIREFIGHTING CAPABILITIES ADJACENT TO PA-C.
3. IRRIGATED & UNIFORMLY LANDSCAPED TREE LAWN TO BE INSTALLED BY DEVELOPER.
4. IF MOUNTABLE CURB IS USED, SIDEWALK WILL ENCREACH 1'-4" INTO TRANSPORTATION EASEMENT.

E. 111th AVENUE FROM BELLE CREEK BLVD TO FLORENCE STREET
(LOCAL RESIDENTIAL WITH DETACHED WALKS, NO ALLEY)

(NOT TO SCALE)

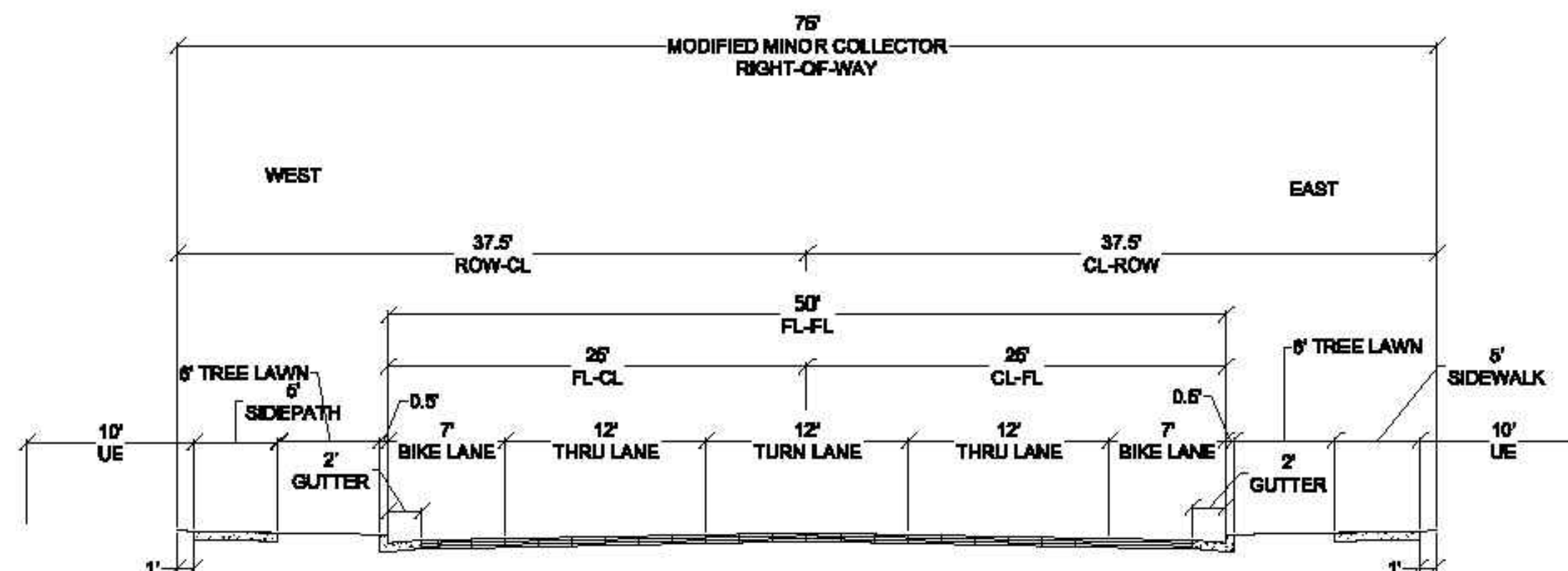

NOTES:

1. CENTER LINE STRIPE REQUIRED.
2. NO PARKING WILL BE PERMITTED IN THE MODIFIED MINOR COLLECTOR SECTION.

FLORENCE STREET FROM E. 112th AVENUE TO E. 111th AVENUE
(MODIFIED MINOR COLLECTOR)

(NOT TO SCALE)

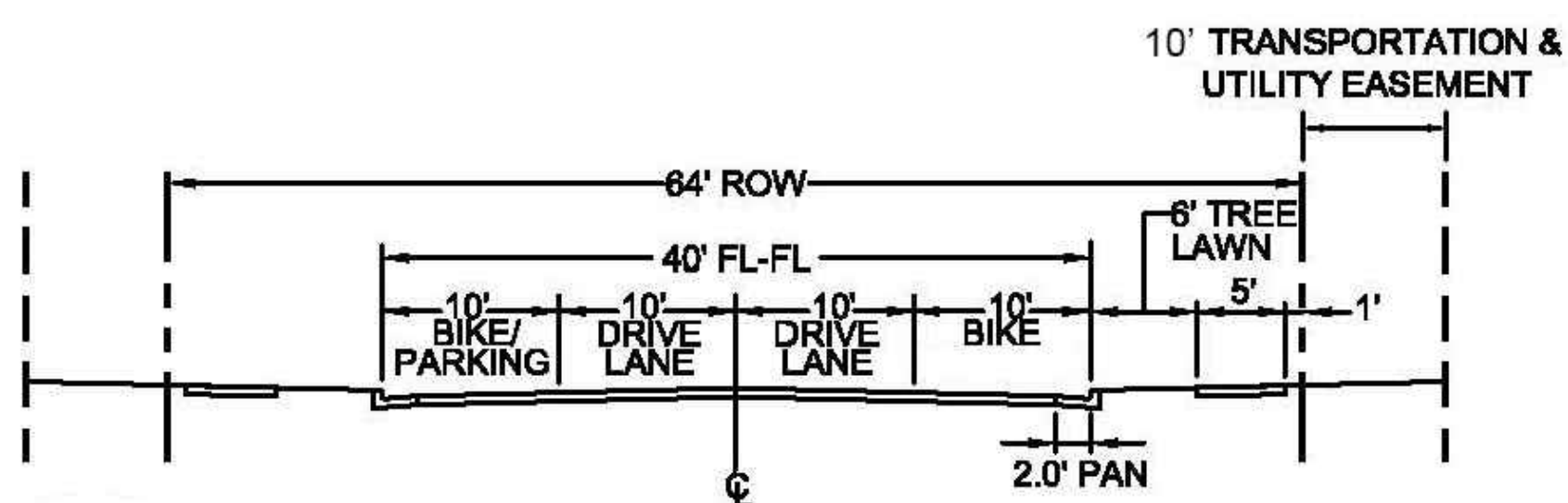

NOTES:

1. CENTER LINE STRIPE REQUIRED.
2. THIS SECTION FOR STREETS ADJACENT TO THE CANAM PROPERTY.
3. NO PARKING PERMITTED WHEN NEEDED FOR FIREFIGHTING CAPABILITIES.

BELLE CREEK BOULEVARD
(MINOR COLLECTOR)

(NOT TO SCALE)

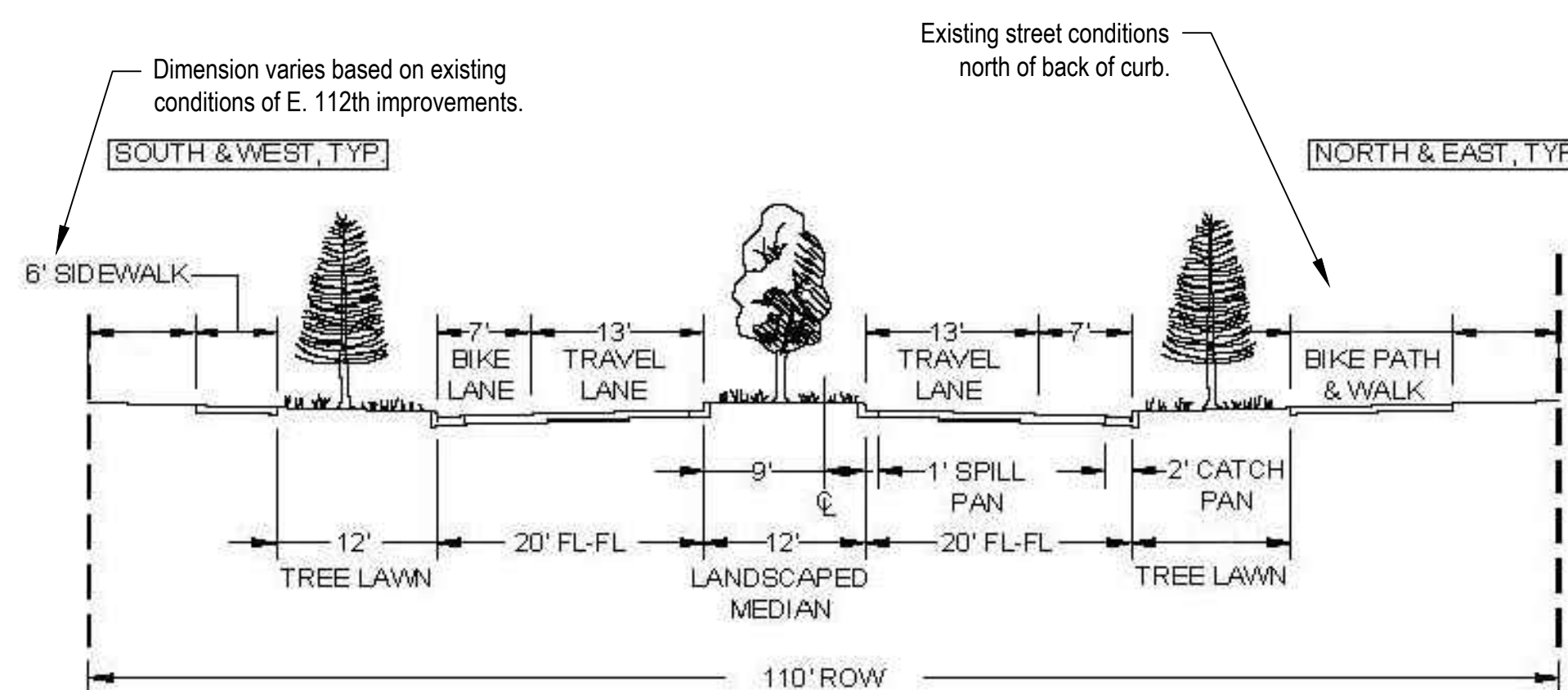

NOTES:

1. AUXILIARY LANES SHALL BE 12' WIDE EXCLUDING GUTTER PANS.
2. EASEMENTS MAY BE DEDICATED AS ROW IF SETBACKS ARE NOT AN ISSUE.
3. SIDEWALKS MAY MEANDER.

E. 112TH AVENUE
(MULTIMODAL ARTERIAL)

(NOT TO SCALE)

CANAM
PLANNED UNIT DEVELOPMENT ZONE DOCUMENT
COMMERCE CITY, COLORADO

OWNER:
Reisbeck Subdivision LLC
2677 S. Clayton Street
Denver, CO 80210

DATE:

10/14/20 PUDZD 01
03/29/21 PUDZD 02
06/01/21 PUDZD 03
08/17/21 PUDZD 04

SHEET TITLE:
STREET
STANDARDS
SHEET NUMBER:
8 OF 10

CANAM PUD ZONE DOCUMENT

A PARCEL OF LAND LOCATED WITHIN SECTION 10, TOWNSHIP 2 SOUTH, RANGE 67 WEST OF THE SIXTH PRINCIPAL MERIDIAN, CITY OF COMMERCE CITY,
COUNTY OF ADAMS, STATE OF COLORADO

ALLEYS

12' PRIVATE ALLEY | No Utilities, No Fire Access NOT TO SCALE

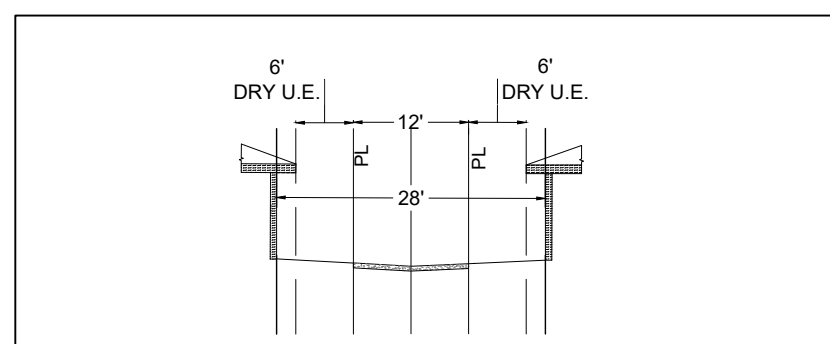

20' PRIVATE ALLEY | Sanitary or Water, Fire Access NOT TO SCALE

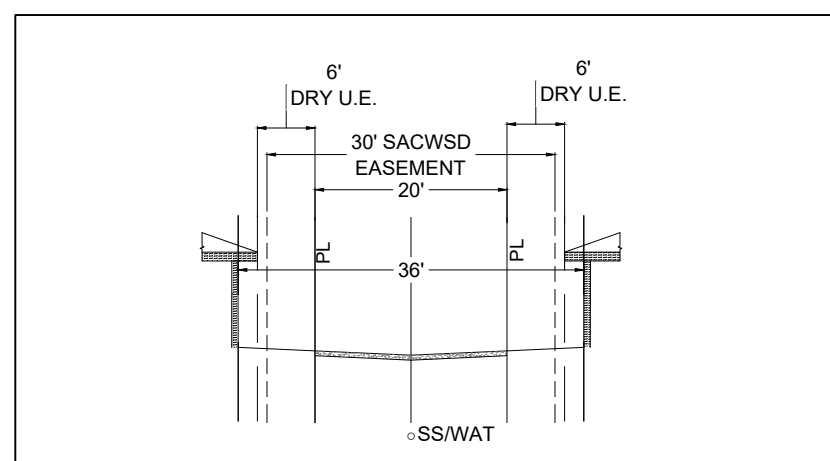

26' PRIVATE ALLEY | Wat, SS, NP and Fire Access NOT TO SCALE

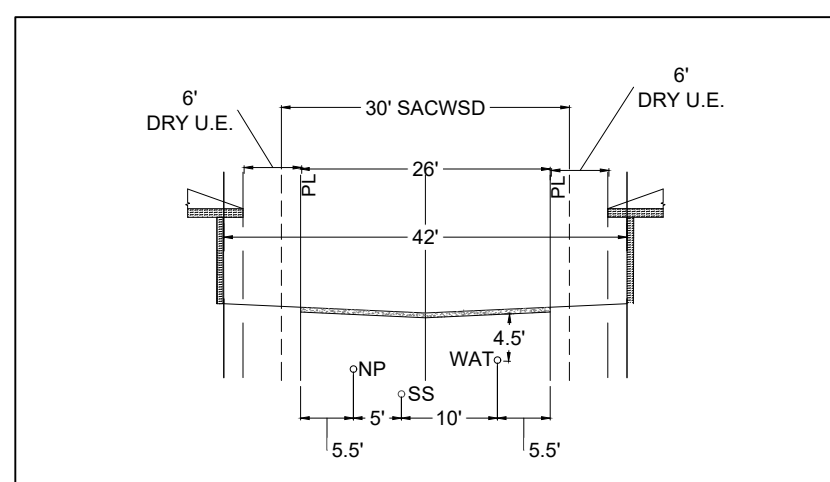

30' PRIVATE ALLEY | Wat, SS, NP, STM, and Fire Access NOT TO SCALE

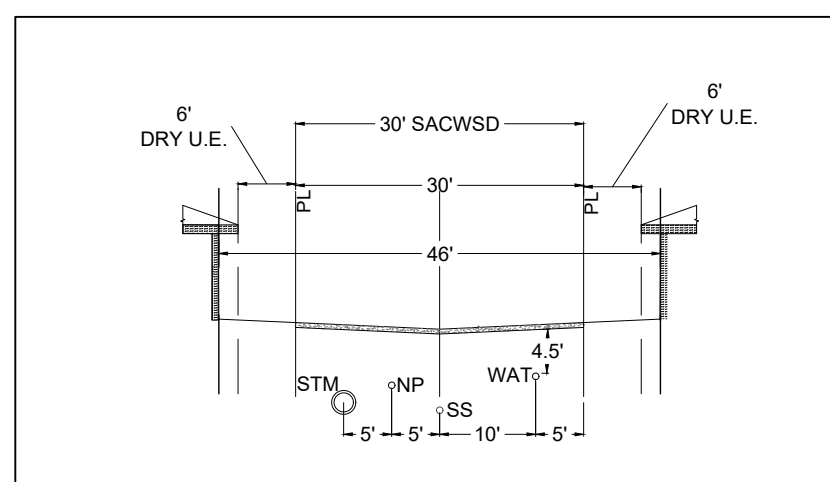

KEY

- WAT - Water
- SS - Sanitary Sewer
- STM - Storm Sewer
- NP - Non-Potable Water
- UE - Utility Easement
- PL - Pavement Line

*Setbacks depicted include 2' roof overhang encroachment as noted in bulk standards table (Sheet 4)

ALLEY USAGE GENERAL NOTES

1. Garages can be either attached or detached.
2. Rear yard fencing on alleys shall be set back from the garage door face a minimum of 12 inches.
3. Alleys shall be private tracts owned by HOA or Metro Districts.
4. All alley networks longer than 150' must have, at a minimum, two access points to a street or acceptable paved vehicular turn around.
5. Minimum pavement width for alleys is 12'.
6. Other parking configurations are permitted, including tandem garages, so long as a 30' separation between buildings across the alley is maintained.
7. Building permit applications shall list alley setbacks as Type A, B, C or N/A (Not Applicable).
8. Alleys proposed to provide fire service are subject to current fire standards, so as to preserve the health, safety, and welfare of users.
9. Minimum pavement width for alleys proposed to provide fire service is 20'.
10. Alley tract widths are subject to change dependant on utility spacing and parking requirements.

ALLEY END CAP DETAIL

NOT TO SCALE

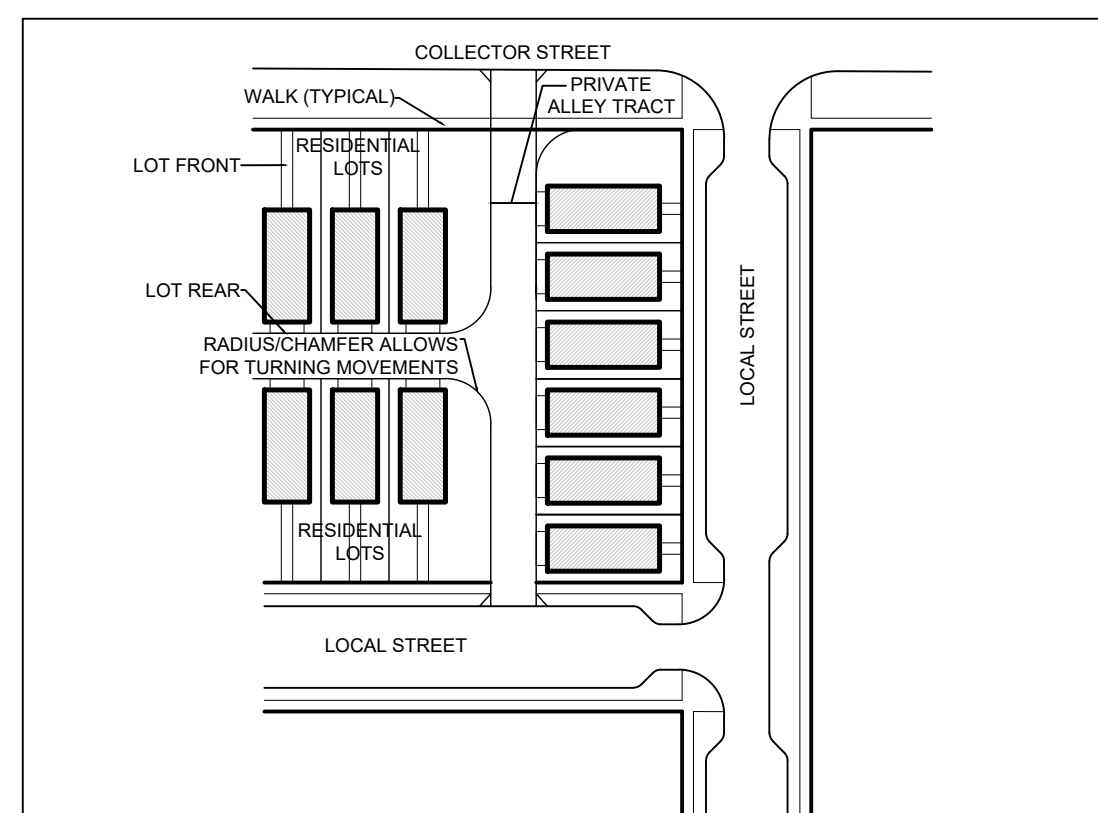

ALLEY PARKING CONDITIONS

NOT TO SCALE

NOTES

1. All parking configurations are permitted in single-family detached and single-family attached layouts, per the setbacks specified in the alley setback table on this sheet and Bulk Standards chart on Sheet 5.
2. All homes on an alley will either all allow parking or all disallow parking. Mixing of parking and no parking configurations is not permitted on a single alley. When parking is prohibited, no parking signs shall be posted according to City standards.

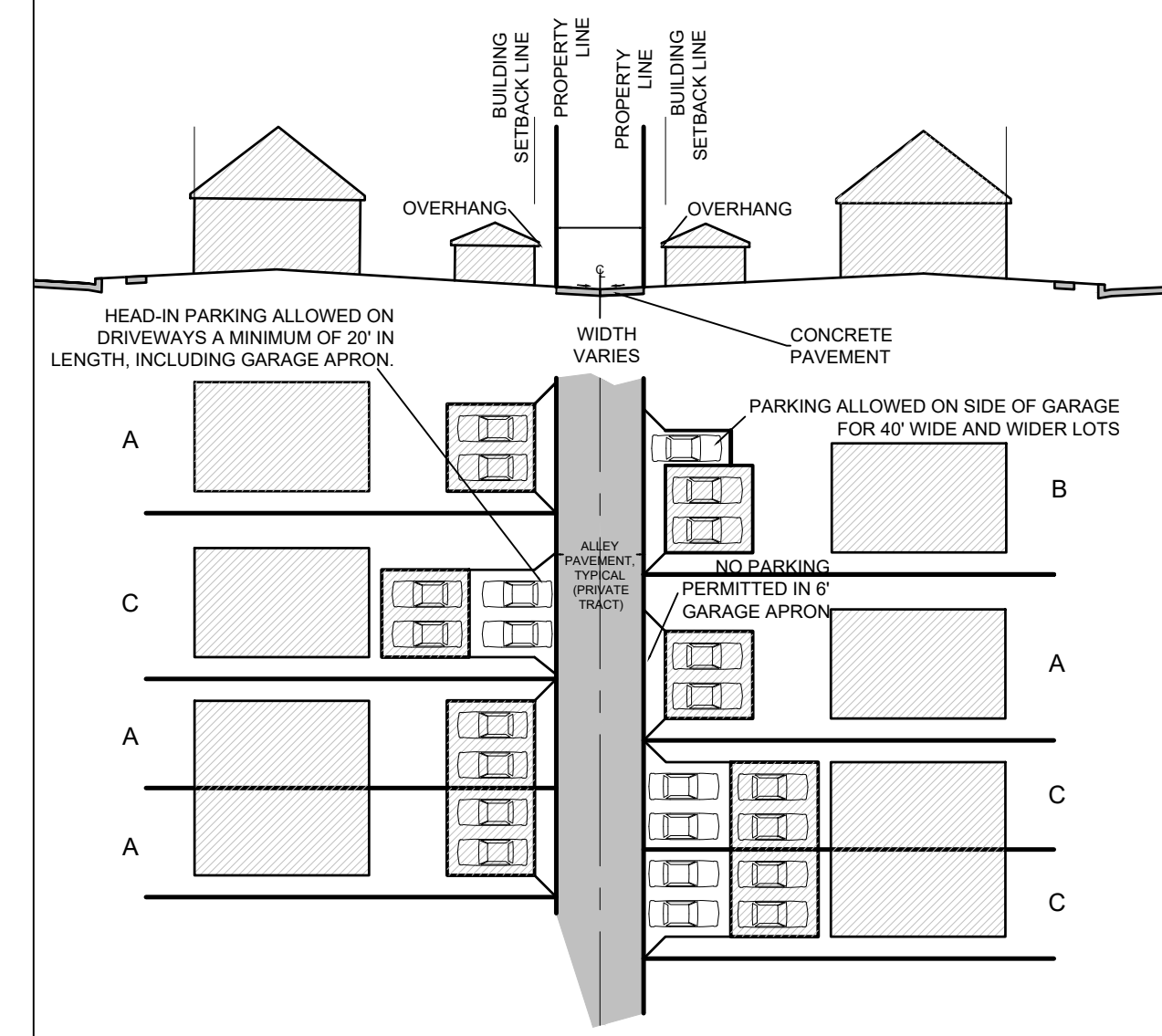

CANAM
PLANNED UNIT DEVELOPMENT ZONE DOCUMENT
COMMERCE CITY, COLORADO

OWNER:
Reisbeck Subdivision LLC
2677 S. Clayton Street
Denver, CO 80210

DATE:

10/14/20 PUDZD 01
03/29/21 PUDZD 02
06/01/21 PUDZD 03
08/17/21 PUDZD 04

SHEET TITLE:
ALLEY
STANDARDS

SHEET NUMBER:
9 OF 10

CANAM PUD ZONE DOCUMENT

A PARCEL OF LAND LOCATED WITHIN SECTION 10, TOWNSHIP 2 SOUTH, RANGE 67 WEST OF THE SIXTH PRINCIPAL MERIDIAN, CITY OF COMMERCE CITY,
COUNTY OF ADAMS, STATE OF COLORADO

SIGNAGE PACKET

WALL SIGNS (IBD-20) NOT TO SCALE

Wall signs for fuel signs composed of individual raised letters may contain 2 s.f. of sign area for each linear foot of building or tenant frontage not to exceed 200 s.f. in area.

CANOPY SIGNS (IDC-20) NOT TO SCALE

Canopy signs for fuel sales are subject to the following standards:

- May project 4" above the top of the canopy.
- Are permitted on each side of the canopy.
- Are permitted a vertical dimension of no greater than 120% of the vertical dimension of the canopy fascia.
- Shall be no greater than 21 square feet in sign area per logo.

MONUMENT SIGNS NOT TO SCALE

Monument signs for fuel sales are subject to the following standards:

- Are permitted a maximum area of 105 square feet per side
- Shall have a maximum height of 8 feet and setback at least 10 feet from property line.

In addition to the above standards, monument fuel price signs are subject to the following standards:

- The fuel price portion of the sign shall not exceed 8 feet in height.
- Shall not exceed 34 square feet in sign area per face.
- Monument signs should feature a masonry brick base that matches the building construction.

* Note: Signage proposed with future residential filings will be subject regulations of the Commerce City Land Development Code.

SIGN LOCATION DIAGRAM NOT TO SCALE

Sign Location Diagram is for use in depicting potential locations for various types of signs typically affiliated with a retail store with fuel sales, and is subject to change.

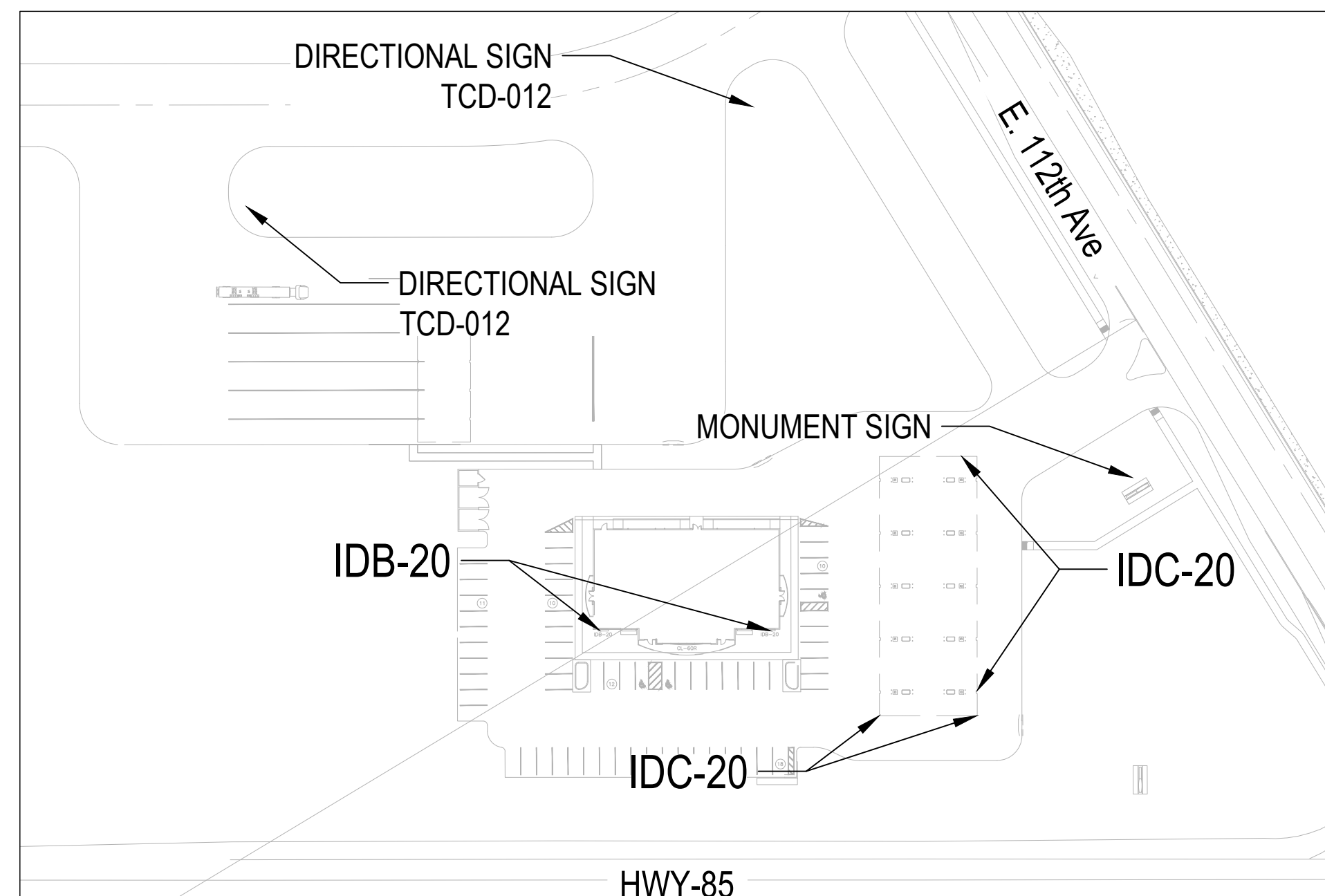

SITE PLAN IS CONCEPTUAL AND SUBJECT TO CHANGE

DIRECTIONAL SIGN - TCD-012

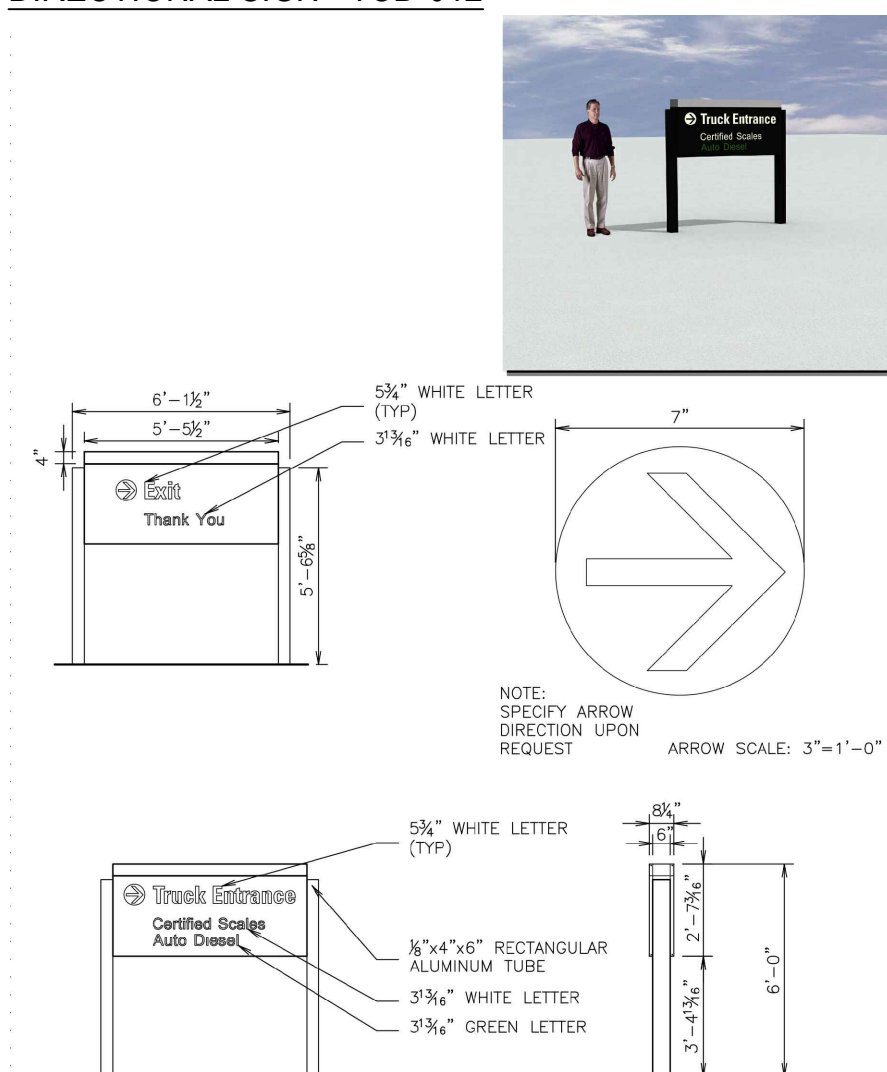

CANAM
PLANNED UNIT DEVELOPMENT ZONE DOCUMENT
COMMERCE CITY, COLORADO

OWNER:
Reisbeck Subdivision LLC
2677 S. Clayton Street
Denver, CO 80210

DATE:
10/14/20 PUDZD 01
03/29/21 PUDZD 02
06/01/21 PUDZD 03
08/17/21 PUDZD 04

SHEET TITLE:
SIGNAGE
STANDARDS
SHEET NUMBER: