

POTOMAC FARMS

FIRST AMENDMENT - PUD ZONE DOCUMENT

A PORTION OF THE SOUTHEAST 1/4 OF SECTION 12,
TOWNSHIP 2 SOUTH, RANGE 67 WEST,
STATE OF COLORADO, COUNTY OF ADAMS, CITY OF COMMERCE CITY

LEGAL DESCRIPTION

A PORTION OF THE SOUTHEAST 1/4 OF SECTION 12, TOWNSHIP 2 SOUTH, RANGE 67 WEST OF THE 6TH PRINCIPAL MERIDIAN, COUNTY OF ADAMS, STATE OF COLORADO. MORE PARTICULARLY DESCRIBED AS FOLLOWS:

COMMENCING AT THE SOUTHEAST CORNER OF SAID SECTION 12, THENCE N 44° 57'48" W, A DISTANCE OF 42.33 FEET TO THE POINT OF BEGINNING;

THENCE, S 89, 59'38" W, ALONG A LINE 30.00 FEET NORTH OF AND PARALLEL TO THE SOUTH LINE OF THE SAID SOUTHEAST 1/4, A DISTANCE OF 2,612.87 FEET TO A POINT ON THE WEST LINE OF THE SAID SOUTHEAST 1/4; THENCE, N 00° 20'13" E, ALONG THE WEST LINE OF THE SAID SOUTHEAST 1/4, A DISTANCE OF 1,290.76 FEET TO A POINT; THENCE DEPARTING SAID WEST LINE, S 89° 56'01" E, A DISTANCE OF 1,320.00 FEET TO A POINT; THENCE, N 00° 20'13" E, A DISTANCE OF 1,320.00 FEET TO A POINT ON THE NORTH LINE OF THE SAID SOUTHEAST 1/4; THENCE, S 89, 56'01" E, ALONG THE NORTH LINE OF THE SAID SOUTHEAST 1/4, A DISTANCE OF 1,291.33 FEET TO A POINT; THENCE DEPARTING SAID NORTH LINE, S 00° 18'13" W ALONG A LINE 30.00 FEET WEST OF AND PARALLEL TO THE EAST LINE OF THE SAID SOUTHEAST 1/4, A DISTANCE OF 2,607.45 FEET TO THE POINT OF BEGINNING.

CONTAINING 5,072,770 SQUARE FEET OR 116.455 ACRES MORE OR LESS

BASIS OF BEARING

THE WEST LINE OF THE SOUTHEAST ONE-QUARTER OF SECTION 12 IS ASSUMED TO BEAR N 00° 20'13" E

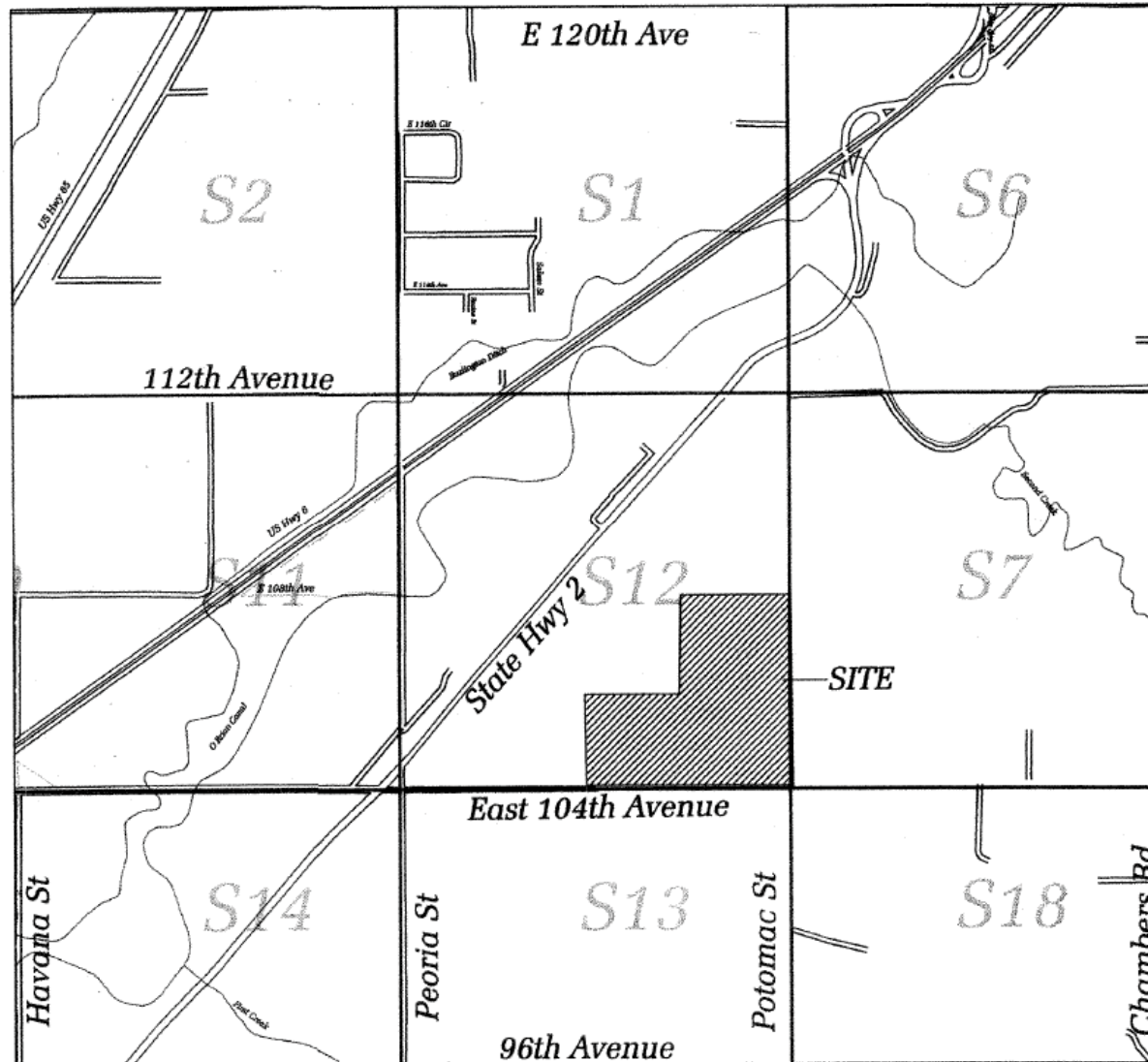

VICINITY MAP

SCALE: 1"=2500'



GENERAL PURPOSE NOTES:

1. THE PURPOSE OF THIS FIRST AMENDMENT IS TO MODIFY THE APPROVED POTOMAC FARMS PUD TO ALLOW ADDITIONAL ENTRYWAY SIGNS. THIS WILL INCLUDE MODIFYING THE SIGN SCHEDULE AND LANGUAGE FOUND IN THE PUD ZONE DOCUMENT.
2. THE GOAL OF THIS AMENDMENT IS TO ENHANCE THE POTOMAC FARMS IDENTITY THROUGH EXCELLENCE IN SIGN DESIGN AT THE ENTRY POINTS OF THE COMMUNITY BY ALLOWING ALL ENTRANCE TO HAVE THE DISTINCT COMMUNITY IDENTIFICATION TO PROVIDE A BALANCED APPEAL.
3. THE INTENT OF THIS AMENDMENT IS TO HAVE ALL NEW ENTRYWAY SIGNS MATCH THE DESIGN AND SIZE OF THE PREVIOUSLY APPROVED SIGNS IN THIS COMMUNITY.
4. EACH ENTRY POINT SHALL BE ALLOWED TO HAVE SIGNAGE AND / OR LANTERN ELEMENTS AS DEFINED IN THIS PUD.

SHEET INDEX:

1. COVER PAGE
2. PUD DESCRIPTION AND DETAILS

City Approval:
Approval of the Commerce City Planning Commission:
Approved this _____ day of _____, 2022

Chairperson _____

Approval of the City Council of the City of Commerce City:
Approved this _____ day of _____, 2022

City Clerk _____

Mayor _____

Adams County Clerk and Recorder:
This PUD Zone Document was filed for record in the office of Adams County Clerk and Recorder in the State of Colorado at _____ m, this _____ day of _____, 2022

By: _____
County Clerk and Recorder

OWNER'S CERTIFICATE

I, _____
being the owner/lien holder of the property located in the County of Adams, State of Colorado, City of Commerce City, do hereby submit this Planned Unit Development Amendment and agree to perform under the terms stated herein.

POTOMAC FARMS METROPOLITAN DISTRICT

By: HARRISON TANKSLEY
Title: Board President

Acknowledgement:
State of Colorado
County of Adams
City of Commerce City
The foregoing instrument was acknowledged by me this _____ day of _____, 2022.

Notary Public _____

My Commission Expires _____

Reception Number: _____



Denver
11220 E. 53rd Avenue, Suite 300
Denver, CO 80239
303-375-9933
Colorado Springs
5011 List Drive
Colorado Springs, CO 80919
719-385-0104

This drawing was created to assist you in visualizing our proposal. The original ideas herein are the property of YESCO. Permission to copy or revise this drawing can only be obtained thru a written agreement with YESCO.

© 2021 YESCO LLC
All rights reserved

www.yesco.com

DESIGN PROFESSIONAL:
BRIAN CRIPPIN

PROPERTY OWNER:



METROPOLITAN DISTRICT
12210 BRIGHTON RD #8
HENDERSON, CO 80640
720-541-7725
www.wolfersbergerllc.com

PUD ZONE DOCUMENT
AMENDMENT #1

Date Submitted:

Resubmittals:

DATE	REVISION	DESIGNER

POTOMAC FARMS
FIRST AMENDMENT - PUD ZONE DOCUMENT
 A PORTION OF THE SOUTHEAST 1/4 OF SECTION 12,
 TOWNSHIP 2 SOUTH, RANGE 67 WEST,
 STATE OF COLORADO, COUNTY OF ADAMS, CITY OF COMMERCE CITY

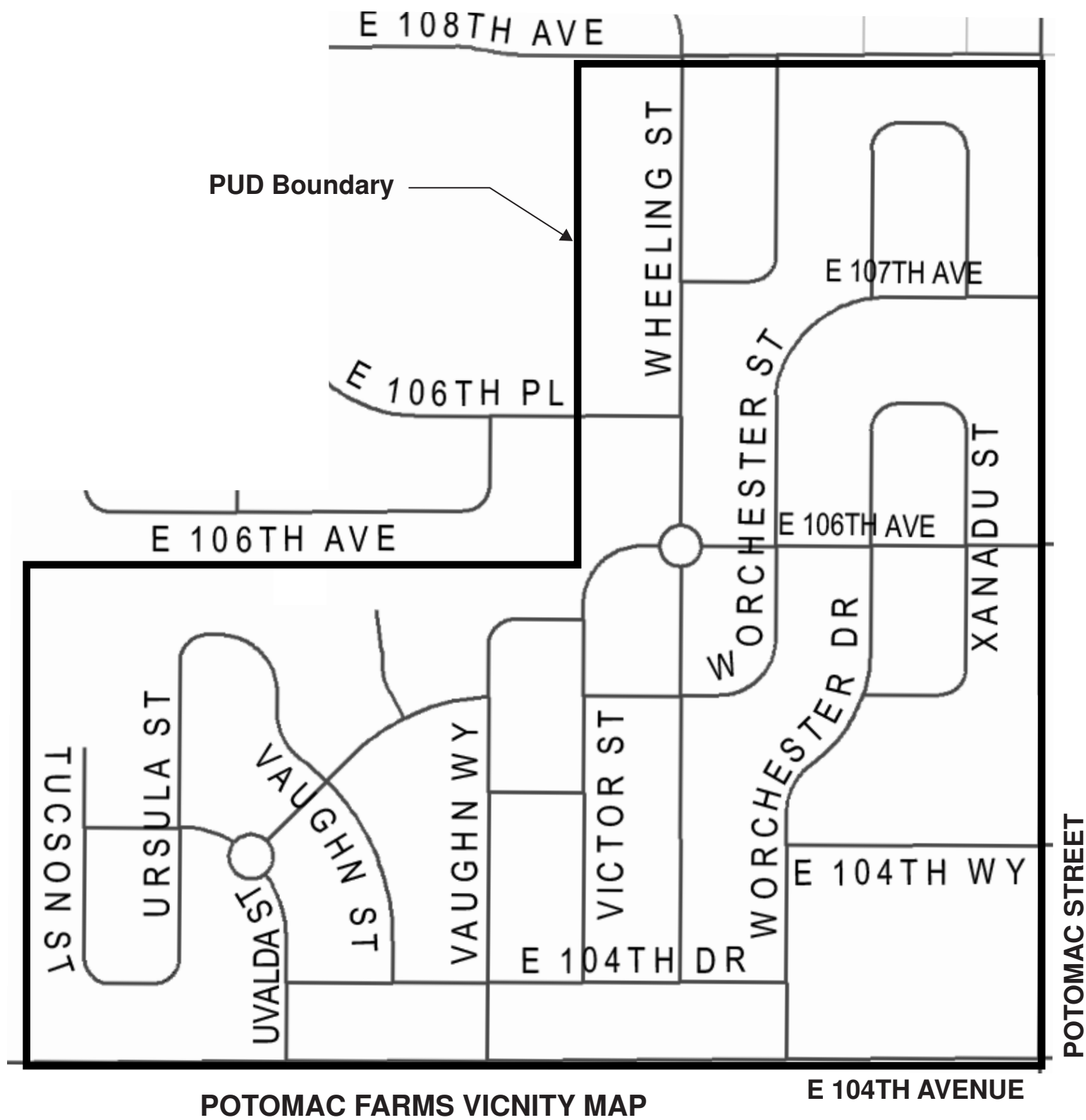

POTOMAC FARMS VICINITY MAP

SIGN SCHEDULE

USE CATEGORY	MAXIMUM ALLOWABLE AREA	SIGN TYPE	SETBACK	HEIGHT	MAXIMUM SIGNS PER USE
*RESIDENTIAL	60 SF (EACH SIGN)	SUBDIVISION ENTRYWAY IDENTIFICATION	MINIMUM 5', OUTSIDE OF ANY SIGHT DISTANCE TRIANGLES	6' TO TOP OF SIGN. 7.75' TO TOP OF ARCHITECTURAL LIGHTING FEATURE.	1 PAIR PER EACH SUBDIVISION ENTRY POINT
**RESIDENTIAL	15 SF (EACH SIGN)	METRO DISTRICT STREET SIGN	MINIMUM 5', OUTSIDE OF ANY SIGHT DISTANCE TRIANGLES	6'	1 PAIR PER EACH SUBDIVISION ENTRY POINT
COMMERCIAL	PER CURRENT COMMERCE CITY LAND DEVELOPMENT CODE AT TIME OF PERMIT.				

* RESIDENTIAL SIGN STANDARDS ARE FOR SUBDIVISION ENTRYWAY IDENTIFICATION. SIGNS MUST BE SIMILAR DESIGN TO EACH OTHER.
 ** RESIDENTIAL SIGN STANDARDS ARE FOR METRO DISTRICT STREET SIGNS. SIGNS MUST BE SIMILAR DESIGN TO EACH OTHER.
 NOTE: NO MONUMENT SIGN SHALL EXCEED 6' IN HEIGHT FROM AVERAGE GRADE NEAR BASE OF SIGN. THE COMMERCE CITY SIGN CODE WILL GOVERN AS APPLICABLE IN INSTANCES WHERE THIS AMENDED SIGN SCHEDULE IS SILENT.

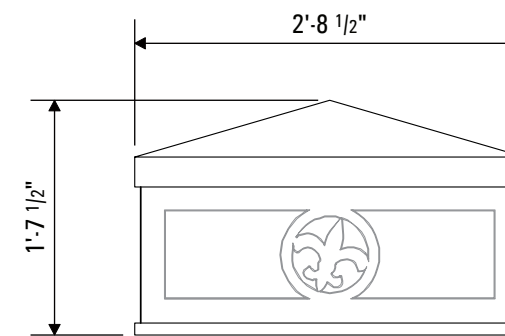

ELEVATION VIEW - LANTERN
 NON-SIGNAGE ELEMENT SCALE: 3/4" = 1'-0"

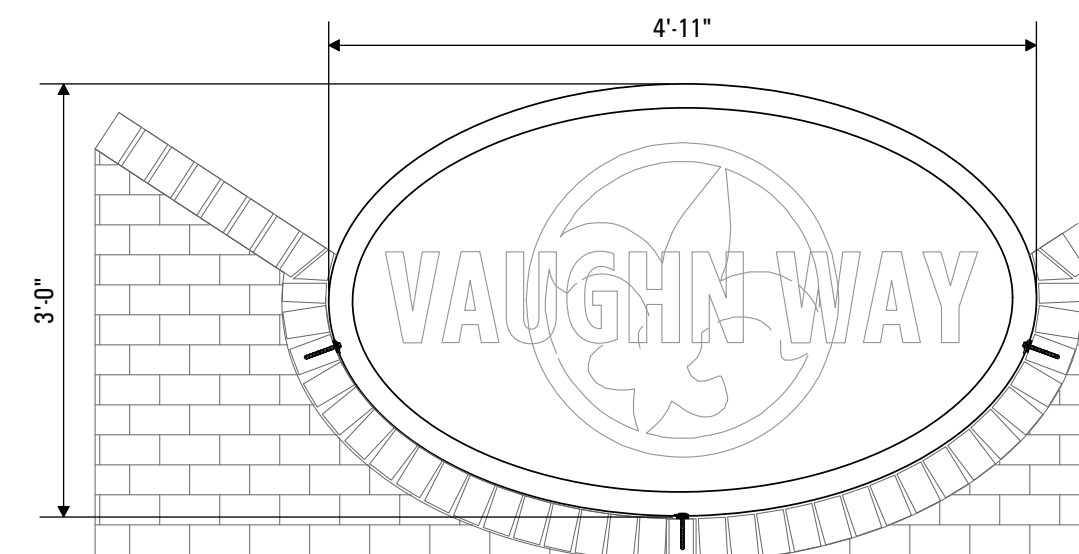

ELEVATION VIEW - LOGO
 METRO DISTRICT STREET SIGN SCALE: 3/4" = 1'-0"

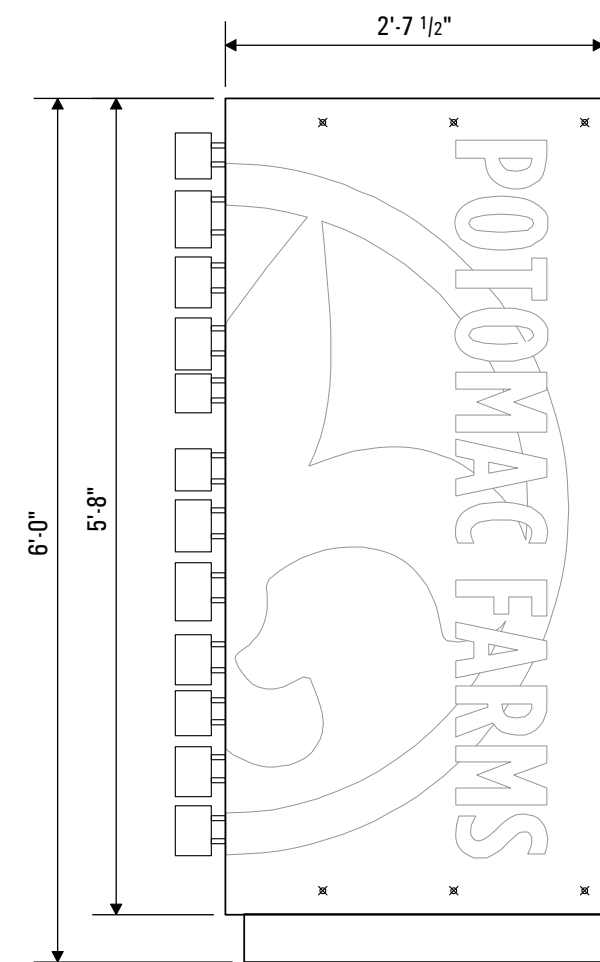

ELEVATION VIEW - PANEL SIGN
 SUBDIVISION ENTRYWAY IDENTIFICATION SCALE: 3/4" = 1'-0"

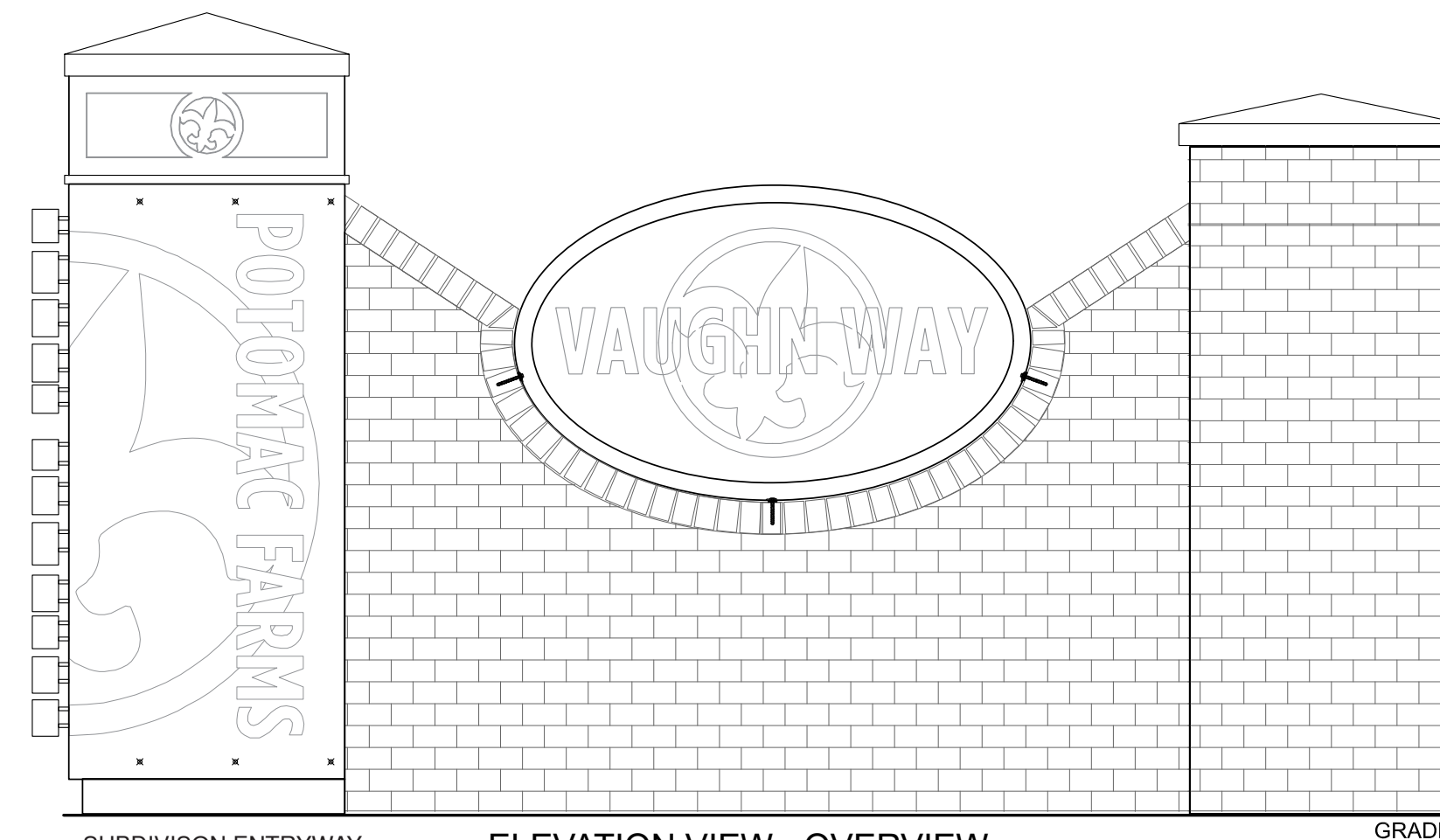

ELEVATION VIEW - OVERVIEW

1. CONTENT IS SUBJECT TO CHANGE AS APPROVED PER PERMIT AND IS NOT REGULATED BY THIS PUD DOCUMENT.
 2. ALL DESIGNS CONTAINED HEREIN ARE CONCEPTUAL AND SUBJECT TO A SIGN PERMIT WITH COMMERCE CITY COMMUNITY DEVELOPMENT.

SHEET INDEX:
 1. COVER PAGE
 2. PUD DESCRIPTION AND DETAILS

Denver
 11220 E. 53rd Avenue, Suite 300
 Denver, CO 80239
 303-375-9933
 Colorado Springs
 5011 List Drive
 Colorado Springs, CO 80919
 719-385-0104

This drawing was created to assist you in visualizing our proposal. The original ideas herein are the property of YESCO. Permission to copy or revise this drawing can only be obtained thru a written agreement with YESCO.

© 2021 YESCO LLC
 All rights reserved
 www.yesco.com

DESIGN PROFESSIONAL:
 BRIAN CRIPPIN

PROPERTY OWNER:



METROPOLITAN DISTRICT
 12210 BRIGHTON RD #8
 HENDERSON, CO 80640
 720-541-7725
 www.wolfersbergerllc.com

PUD ZONE DOCUMENT
 AMENDMENT #1

Date Submitted:

Resubmittals:

DATE	REVISION	DESIGNER